

A black and white photograph of an astronaut in a full space suit standing on the lunar surface. The astronaut is positioned on the left side of the frame, facing right. The background shows the desolate, cratered landscape of the moon under a dark sky. The overall tone is somber and futuristic.

Biomorphed

Lunar Habitat Design

Biophilic Design for Astronaut
Well-being

Tutors: Dr. Dipl.-Ing. Henriette Bier,
Ir. F. Adema, Ir. A. Hidding

Extra-/Terrestrial Architecture Graduation Studio

Maurits Roijen | 5238153

Contents

1. Introduction & Background	3
2. Site Analysis	13
3. Construction & Materialisation	17
4. Mental Health & Well-being	26
5. Biophilic Design	29
6. Programme	42
7. Proof of Concept (Fragment)	44
8. Conclusion	64

INTRODUCTION / BACKGROUND

Return to the Moon

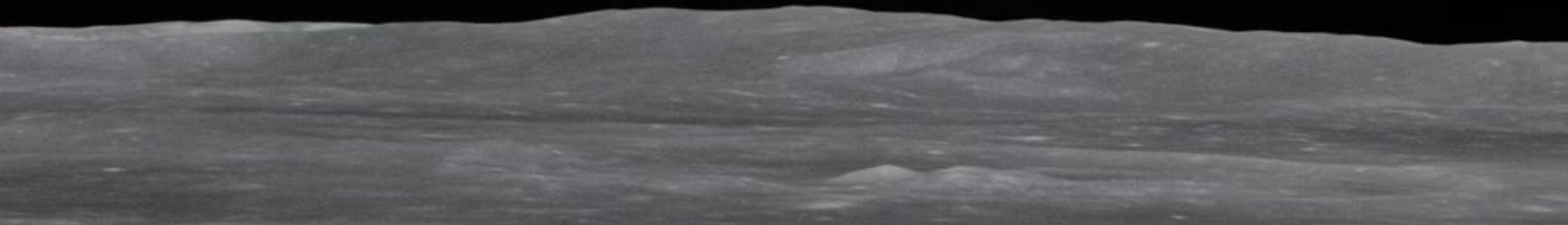

Why is this topic relevant?

- A second space race to put humans on the Moon again
- Involving many space agencies like NASA, ESA, ROSCOSMOS, CNSA, etc.
- Aim for longer term Moon missions
- Eventually leading to colonising of the Moon and beyond



<https://www.nasa.gov/news-release/nasas-artemis-ii-crew-beams-official-moon-flyby-photos-to-earth/>

Lunar habitation faces 3 main challenges

Transportation Costs



Hostile Environment



Mental Health



Transportation Costs

- Expensive to launch rockets
- Price/kg has decreased with reusable rockets
- Building materials are heavy



In-Situ Resource Utilization (ISRU)

poses a solution by reducing the need for transporting materials from earth

<https://www.nasa.gov/overview-in-situ-resource-utilization/>

Hostile Environment

- Abrasive lunar dust
- Moonquakes
- Micro meteorites
- Radiation
- Solar wind
- Long lunar nights
- No atmosphere
- Extreme temperature fluctuations



Lava Tubes

poses a solution by creating a protective cover from the environment in combination with the shelter provided by the habitat

https://bsmedia.business-standard.com/_media/bs/img/article/2019-07/18/full/1563434814-8966.jpg

Mental Health

- Stuck with the same people
- High stress environment
- Away from family and home
- Little privacy



Biophilia

poses a solution by adding more greenery and reminding people of earth. Biophilic design can improve mental health.

<https://www.nasa.gov/image-article/expedition-59-crew-members-inside-u-s-destiny-laboratory/>

UN Sustainable Development Goals

- Health & well-being → Biophilic (human-centric design)
- Innovation → Design-To-Robotic-Production and 3D printing advancements
- Sustainable cities and responsible consumption → ISRU to reduce pollution from transport



Goals

- To design a functional, safe and effective ISRU Lunar habitat
- To explore the relationship between biophilic design and 3D printing
- To create a habitat with a healthy indoor environment for mental wellbeing
- To contribute to the study of future habitats designs on and off Earth

“How can **biophilic design** principles be adapted to a lunar lava tube habitat using **ISRU 3D-printed** architecture to support astronaut **mental health** and **well-being?**”

TEAM SIZE	6 person team, rotate 3 at a time for knowledge transfer	LOCATION	South pole → Lava tube
MISSION TYPE	Longer term research missions on the south pole of the moon	MATERIAL	3D printed lunar regolith
TIMELINE	First lunar base already established. Now in the longer term stay phase.	BUILD	ISRU 3D printing Selective Laser Melting
DESIGN	Different aspects: human-centric, biophilic, circular, computational, advanced manufacturing, life support systems, etc.		

A black and white photograph of a lunar surface. In the background, a rover is visible on a flat plain. The sky is dark with a bright, circular light source, possibly the sun or moon. The foreground shows a deep, dark crater or depression in the ground. The overall scene is desolate and rocky.

SECTION

Site Analysis

Lunar South Pole

Sunlight

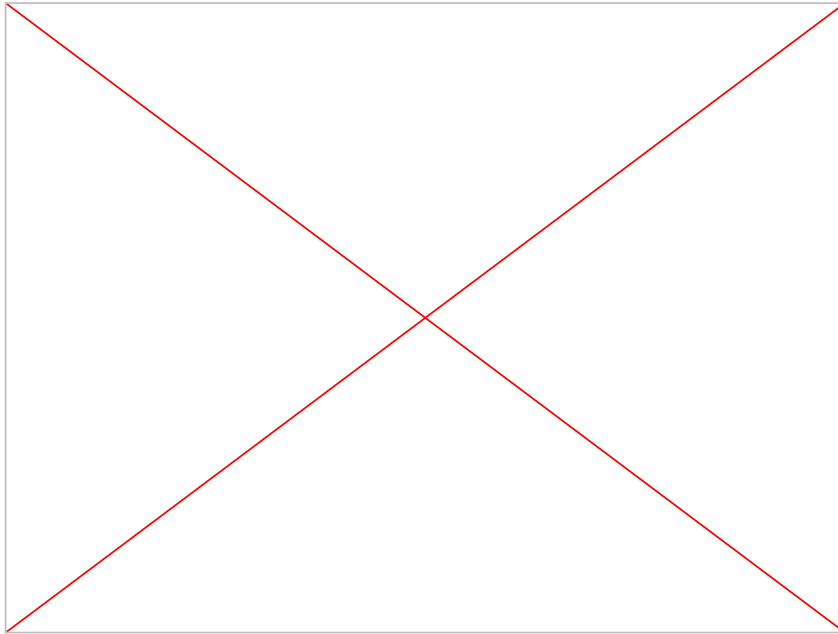

<https://svs.gsfc.nasa.gov/4930/>

Water Ice deposits

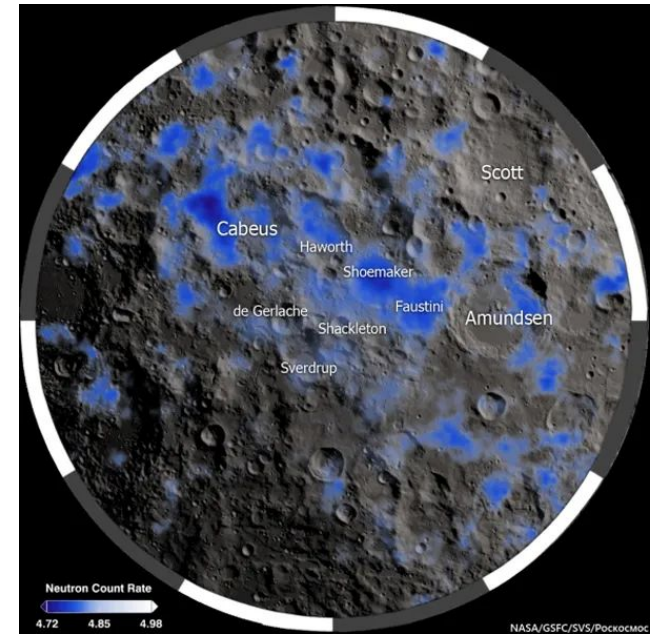

<https://science.nasa.gov/image-detail/svs-lend-20130601-580-2/>

Skylights of theorised lava tubes

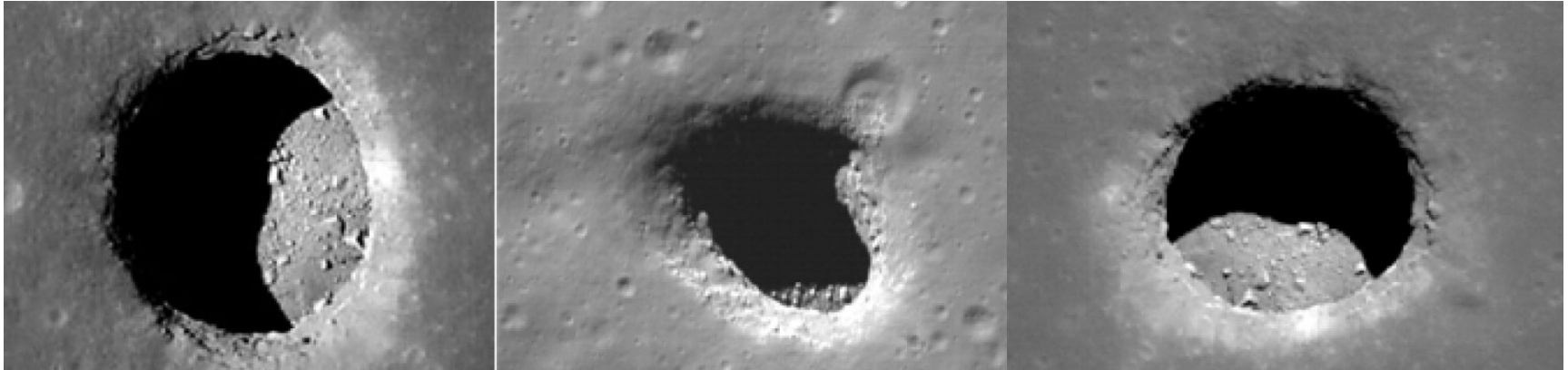

<https://phys.org/news/2020-07-lava-tubes-exploration-priority-worlds.html>

Lunar Lava Tubes

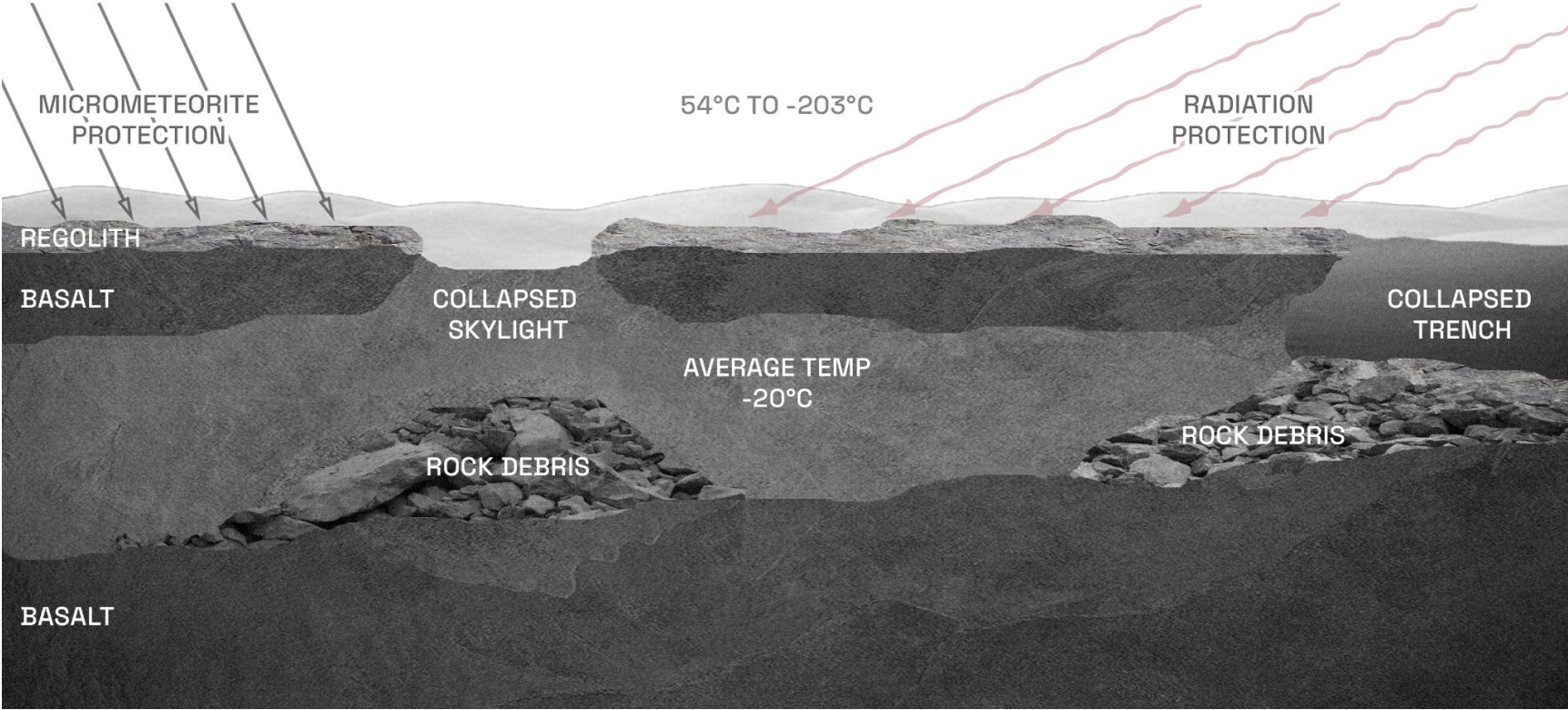

Section

Construction & Materialisation



Extracting Materials



- Water (life support)
- Oxygen (life support)
- Silica (for glass)
- Metal (construction)

Lunar Regolith Composition

Element	Low-Ti Mare Soils	High-Ti Mare Soils	Highland Soils	KREEP Soils
O	60.26	60.30	60.82	60.47
Si	17.30	15.86	16.31	17.35
Al	5.56	5.70	10.66	6.48
Mg	5.53	5.70	3.84	5.39
Ca	4.44	4.60	5.92	4.43
Fe	5.85	5.29	1.90	4.47
Ti	0.66	2.01	0.17	0.62
Na	0.26	0.31	0.29	0.44
K	0.06	0.05	0.05	0.19
Mn	0.08	0.07	0.03	0.06

https://www.researchgate.net/figure/Assumed-Composition-of-the-Lunar-Regolith-and-Variation-Across-Soil-Types-a_tbl1_258661774

https://ntrs.nasa.gov/api/citations/20250003730/downloads/Progress%20Review%20NASA%20Lunar%20ISRU_Sanders.pdf

3D Printing

- Using the top layer of regolith
- Easy to mine with robots
- Need a way to 'print' the dust without additives

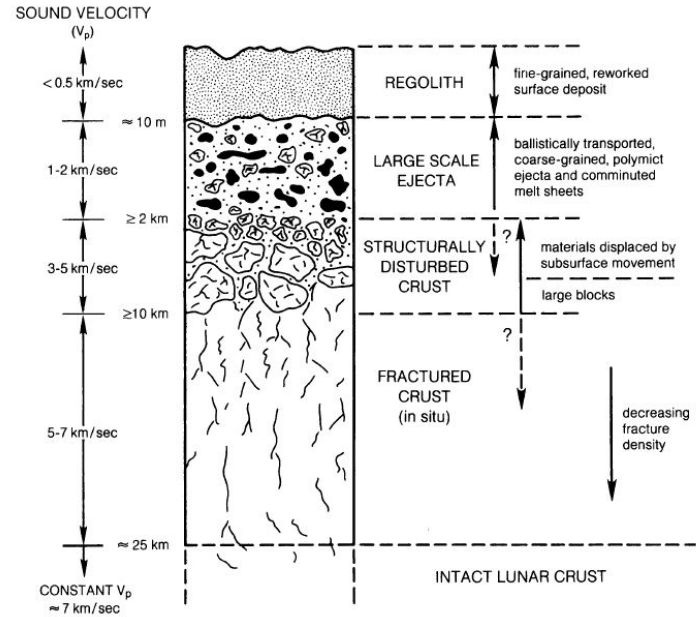

https://www.researchgate.net/figure/The-vertical-structure-of-the-Lunar-regolith-and-crust_fig7_264340952

Robotic Process



COLLECTING

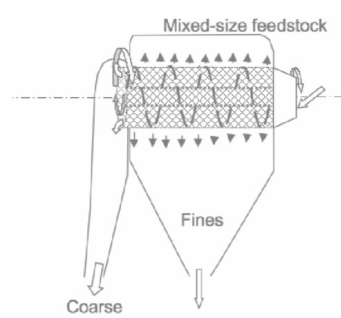

PROCESSING

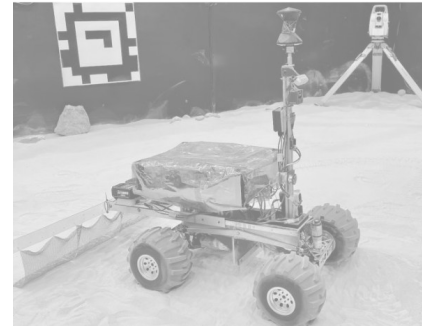

FLATTENING

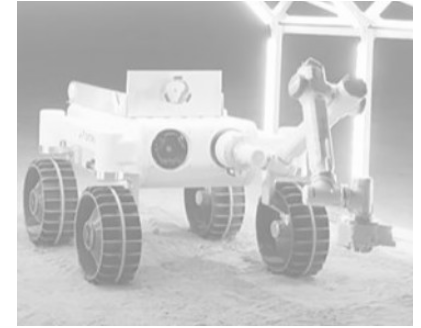

MELTING

https://moonshotplus.tudelft.nl/images/7/7f/1.13.1_Space%26Robotics_FinalPresentation_JIP2025.pdf

Robotic Process

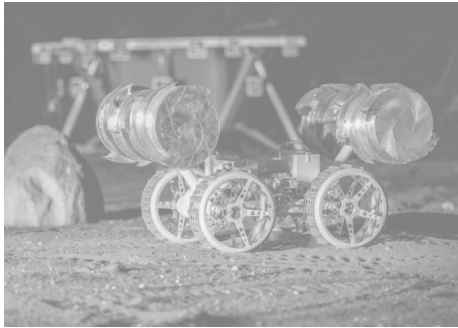

COLLECTING

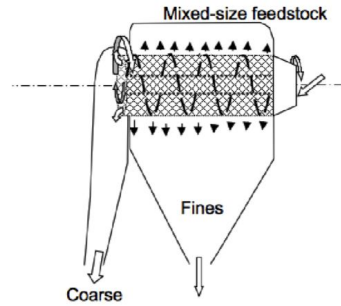

PROCESSING

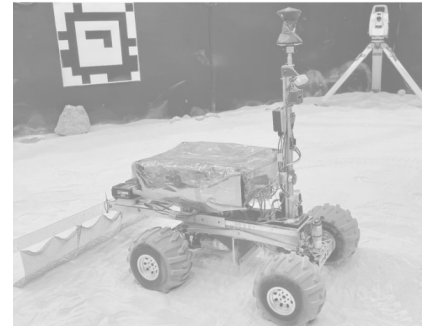

FLATTENING

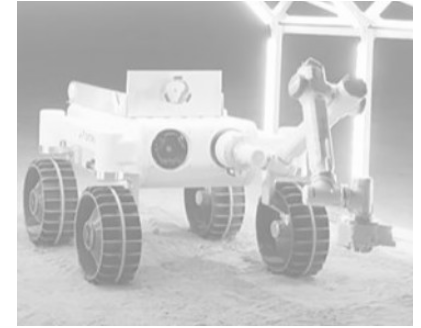

MELTING

https://moonshotplus.tudelft.nl/images/7/7f/1.13.1_Space%26Robotics_FinalPresentation_JIP2025.pdf

Robotic Process

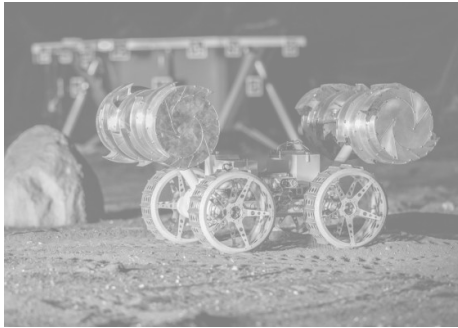

COLLECTING

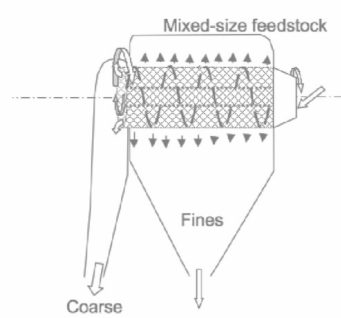

PROCESSING

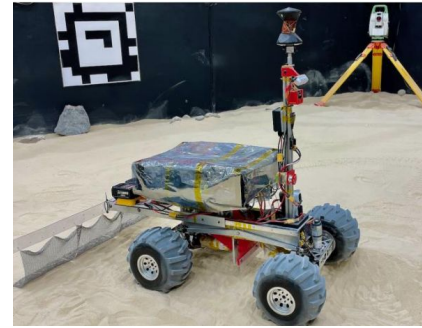

FLATTENING

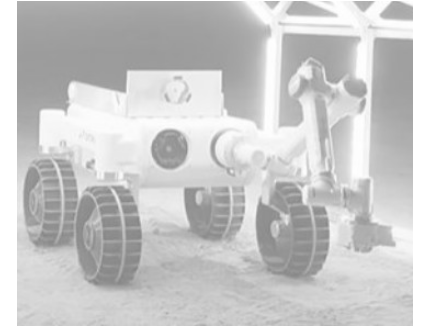

MELTING

https://moonshotplus.tudelft.nl/images/7/7f/1.13.1_Space%26Robotics_FinalPresentation_JIP2025.pdf

Robotic Process

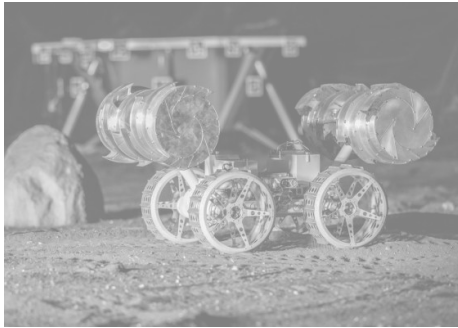

COLLECTING

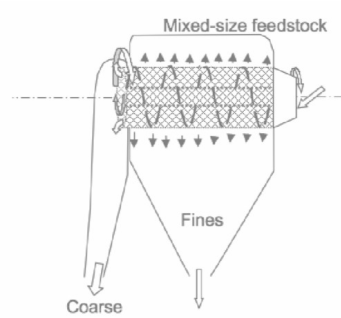

PROCESSING

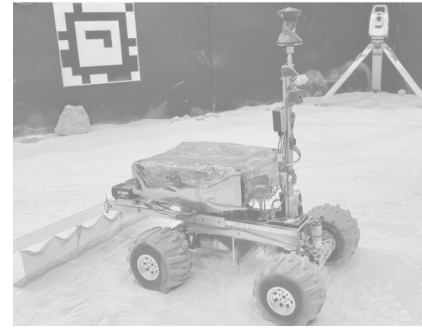

FLATTENING

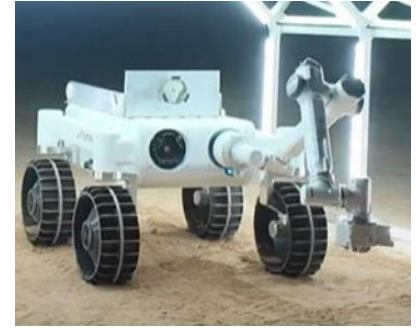

MELTING

https://moonshotplus.tudelft.nl/images/7/7f/1.13.1_Space%26Robotics_FinalPresentation_JIP2025.pdf

Selective Laser Melting (SLM)

- Melts regolith into a glass-like solid
- No additives required
- Energy-intensive
 - 1500 degrees celcius
- Less porous than SLS so better structural integrity

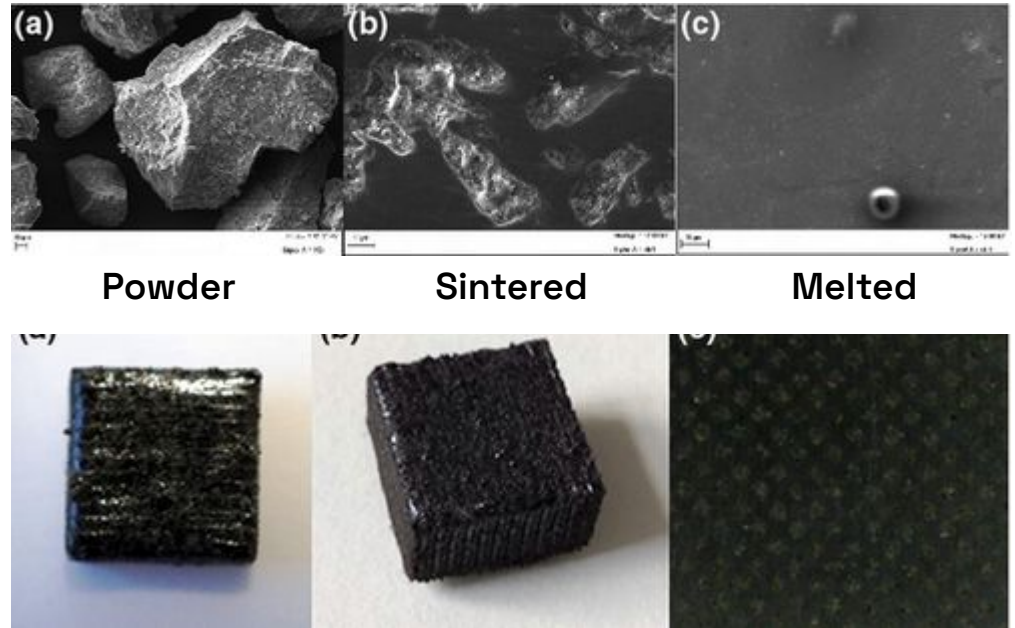

Fateri, M., & Gebhardt, A. (2015). Process parameters development of selective laser melting of lunar regolith for on-site manufacturing applications. *International Journal of Applied Ceramic Technology*, 12(1), 46-52.

Case Study

TECLA by Mario Cucinella Architects

- Used material extrusion not SLM
- Organic shapes
- Custom unique texture on the exterior
- Integrated strip lighting
- Compressive dome shape



Mario Cucinella Architects. (2020). *TECLA: The first eco-sustainable housing prototype 3D printed from raw earth.*
<https://www.mcarchitects.it/en/projects/tecla-technology-and-clay>



Section

Mental Health & Well-being

Missions in Space

- Stuck with the same people
- High stress environment
- Away from family and home
- Little privacy
- Monotonous environment

Sick Building Syndrome

- Improper, harsh lighting
- Thermal/humidity discomfort
- Bad acoustic quality → noise
- Bad air quality

Biophilic Design Interventions Should Respond through:

- Non-monotonous, dynamic spaces
- Separation between public & private spaces → ability to retreat
- Lighting comfort
- Acoustic comfort
- Thermal comfort
- Air quality

Section

Biophilic Design

A black and white photograph of an astronaut in a full space suit walking across a desolate, rocky landscape. The terrain is uneven with scattered rocks and a long shadow cast by the astronaut. The background shows rolling hills under a dark, clear sky. The overall mood is one of isolation and exploration.

Definition

An approach to architecture and interior design that **connects people with nature** within built environments, using **natural elements, forms, and processes** to **improve human health**, well-being, and productivity, stemming from our innate **love for nature**

At the building level biophilic design comes through **2 main design systems**

Lindemayers L-System

A mathematical system that describes plant growth and allows us to model it.

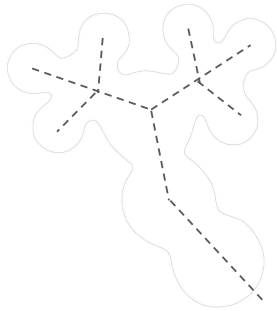

Metaballs

A modelling technique involving spheres to create **organic looking shapes**.

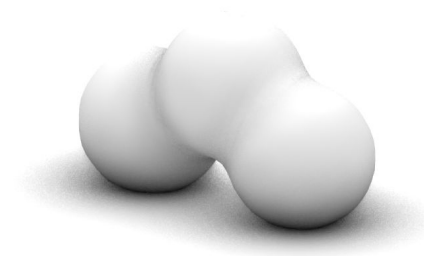

Why L-System?

1. Biomimicry → mimic plant growth
2. Modular design
 - a. Building can grow and branch out in the future
3. Efficient pathing
 - a. L-system branches create pathing for humans and LSS
4. Spatial Hierarchy
5. Compartmentalization (safety)



Why L-System?

1. Biomimicry → mimic plant growth
2. Modular design
 - a. Building can grow and branch out in the future
3. Efficient pathing
 - a. L-system branches create pathing for humans and LSS
4. Spatial Hierarchy
5. Compartmentalization (safety)

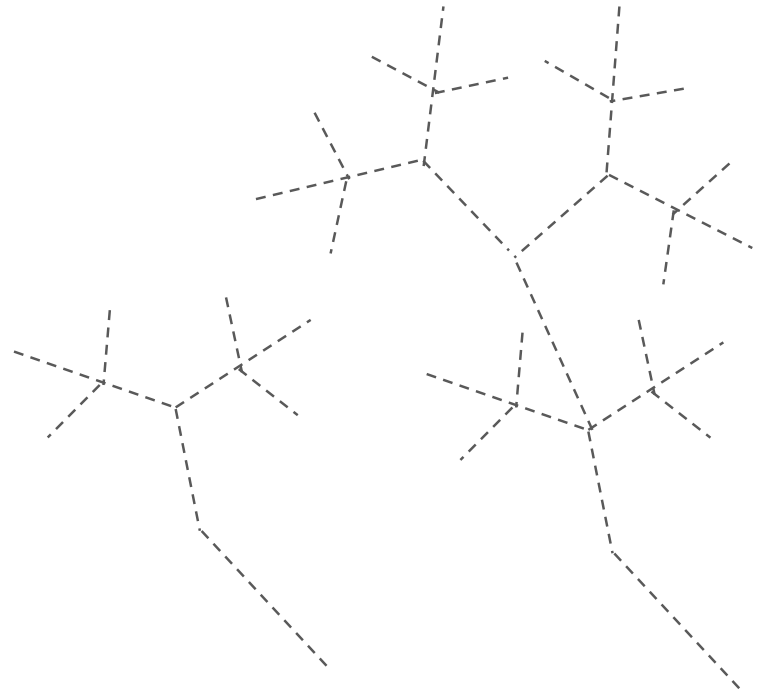

Why L-System?

1. Biomimicry → mimic plant growth
2. Modular design
 - a. Building can grow and branch out in the future
3. Efficient pathing
 - a. L-system branches create pathing for humans and LSS
4. Spatial Hierarchy
5. Compartmentalization (safety)

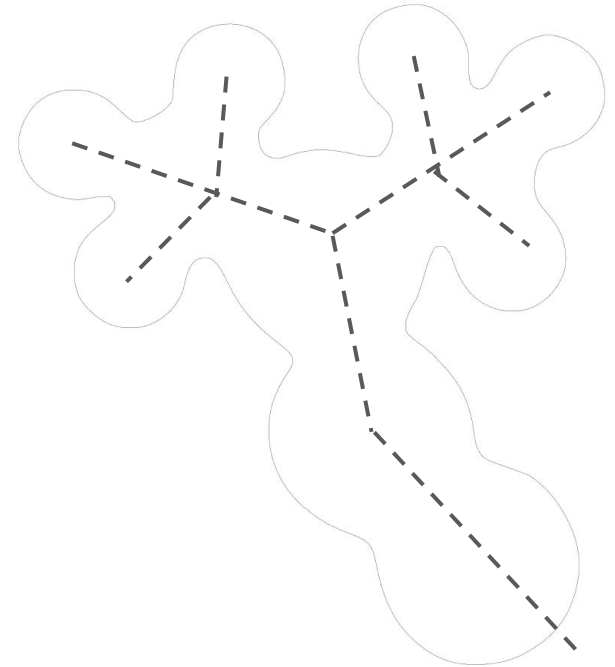

Why L-System?

1. Biomimicry → mimic plant growth
2. Modular design
 - a. Building can grow and branch out in the future
3. Efficient pathing
 - a. L-system branches create pathing for humans and LSS
4. Spatial Hierarchy
5. Compartmentalization (safety)

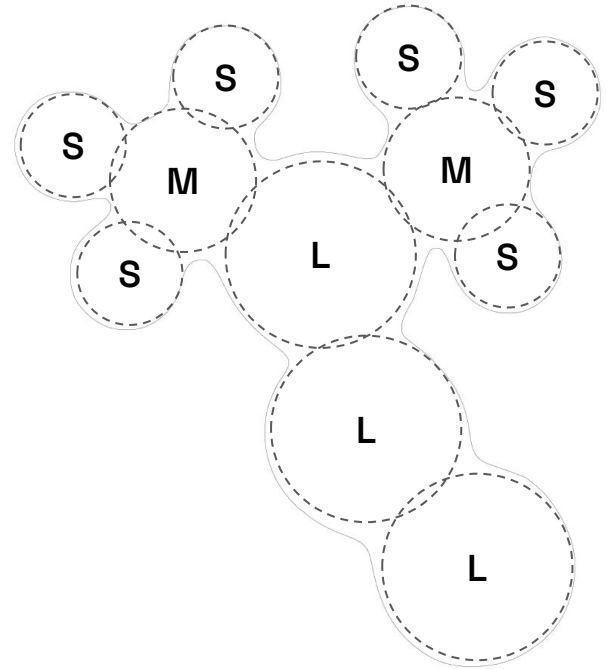

Why L-System?

1. Biomimicry → mimic plant growth
2. Modular design
 - a. Building can grow and branch out in the future
3. Efficient pathing
 - a. L-system branches create pathing for humans and LSS
4. Spatial Hierarchy
5. Compartmentalization (safety)

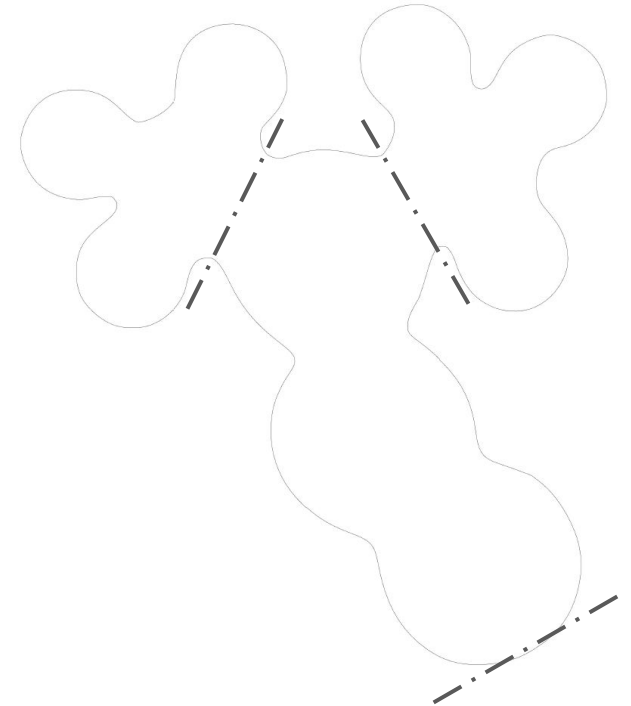

Case Study

Cardiff Bay Opera House by Greg Lynn

- Precedent for designing with L-systems
- Uses the L-system to define the floorplan
- Clear spatial hierarchy through size differences

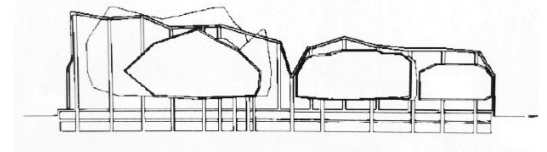
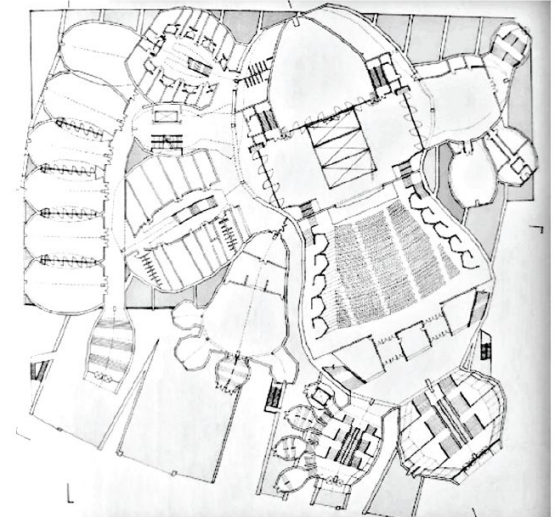
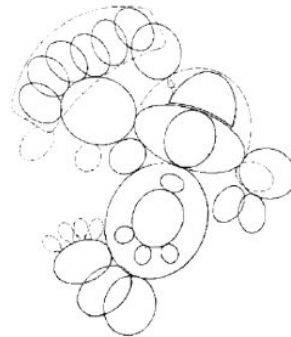
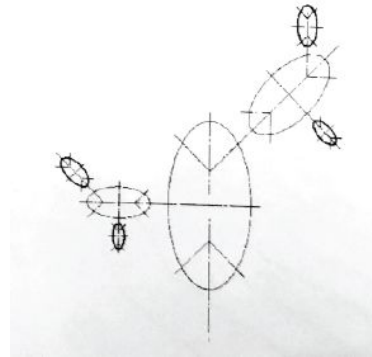

Why Metaballs?

1. 3D printing allows us to step away from more typical orthogonal architectural designs
2. Easy way to achieve an organic look
3. Spheres are ideal shapes when dealing with pressure
4. Domes work well in compression, ideal for 3D printing

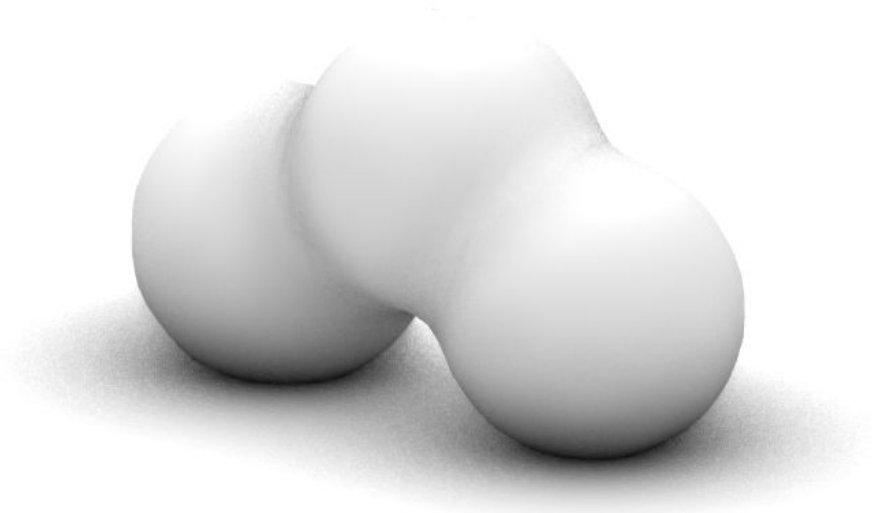

Why Metaballs?

1. 3D printing allows us to step away from traditional blocky looks you find on Earth at the moment
2. Easy way to achieve a dynamic organic form
3. Spheres are ideal shapes when dealing with pressure
4. Domes work well in compression, ideal for 3D printing

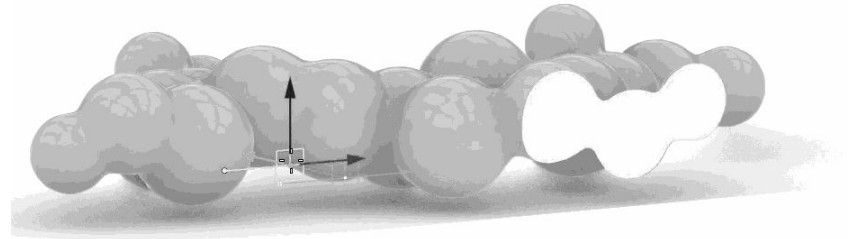

Why Metaballs?

1. 3D printing allows us to step away from traditional blocky looks you find on Earth at the moment
2. Easy way to achieve an organic look
3. Spheres are ideal shapes when dealing with pressure
4. Domes work well in compression, ideal for 3D printing

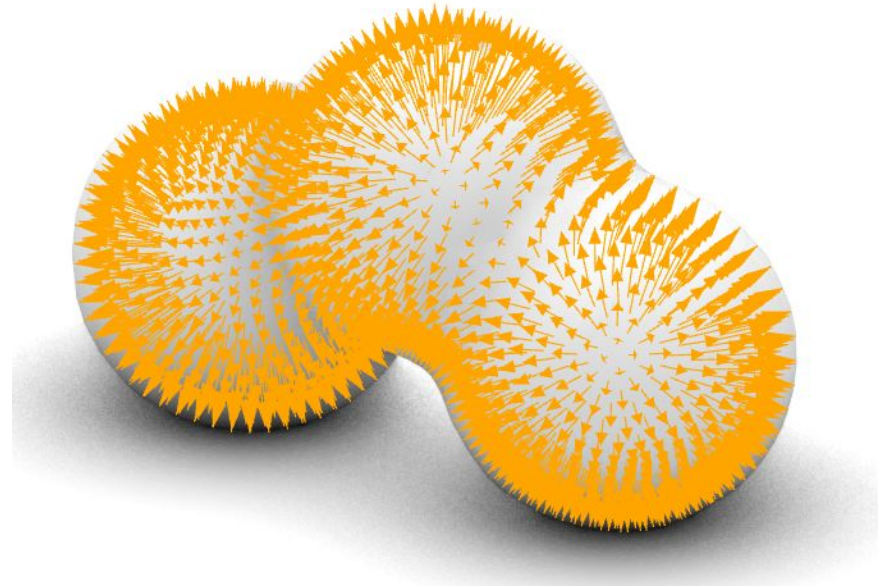

Why Metaballs?

1. 3D printing allows us to step away from traditional blocky looks you find on Earth at the moment
2. Easy way to achieve an organic look
3. Spheres are ideal shapes when dealing with pressure
4. Domes work well in compression, ideal for 3D printing

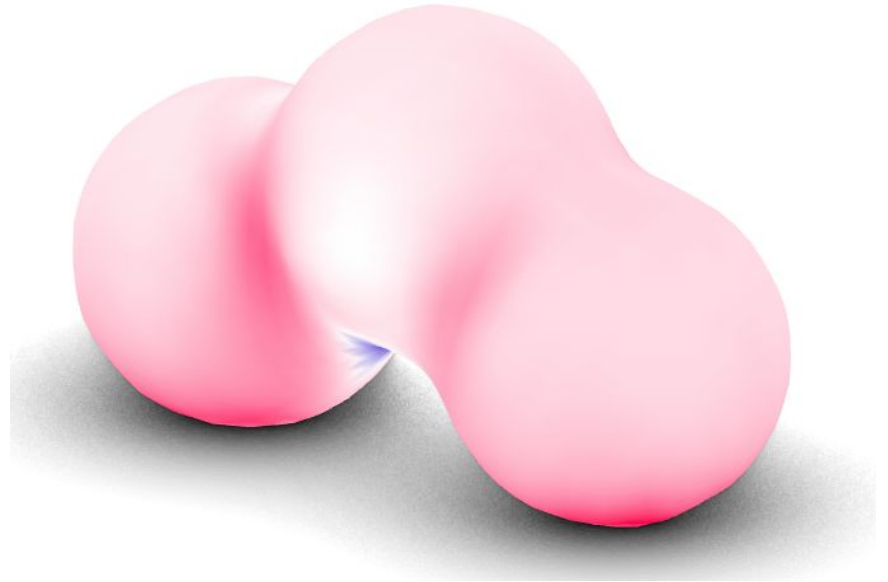

A black and white photograph of an astronaut in a full spacesuit standing on the surface of Mars. The astronaut is positioned on the left side of the frame, facing slightly towards the right. The background shows the undulating, sandy dunes of the Martian landscape under a dark sky. In the foreground, there is a dark, circular shadow cast by the astronaut. To the right, there is a piece of scientific equipment on a tripod. The overall scene is desolate and emphasizes the isolation of the Mars mission.

Section

Programme

Long-Term Research Mission For A Crew Of 6

TYPOLOGY		SIZE							ACTIVITY			PRIVACY			EXTERIOR	
PROGRAMME	ROOM	AREA 1 Person (m2)	Max. Capacity	MIN. AREA (m2)	Number of rooms	Total floor area (m2)	% OF HABITAT	MIN. HEIGHT (m)	CATEGORY	CROSS-FUNCTION	Details	CAPACITY	VISIBILITY	ACOUSTICS	ACCESS	VIEW
Dirty Zone	Airlock (EVA Prep)	8	3	24	2	48	9.14%	3	Support	/		Small groups (2-3)	Enclos...	Neutral	Yes	No
	Lunar Soil Lab	12	2	24	1	24	4.57%	3	Work	/		Large groups (4-6)	Enclos...	Neutral	No	No
	Geology Lab	12	2	24	1	24	4.57%	3	Work	/		Large groups (4-6)	Enclos...	Neutral	No	No
	System Maintenance	8	1	8	1	8	1.52%	3	Support	/		Small groups (2-3)	Enclos...	Neutral	No	No
	Storage (outdoor equipment)	4	3	12	1	12	2.29%	3	Support	/		Storage	Enclos...	Neutral	Yes	No
Core Utility Zone	Life Support Systems	8	1	8	1	8	1.52%	3	Support	/		Small groups (2-3)	Enclos...	Sound ...	No	No
	Systems Maintenance	8	1	8	1	8	1.52%	3	Support	/		Small groups (2-3)	Enclos...	Sound ...	No	No
	Storage (food, water, oxygen)	8	3	24	1	24	4.57%	3	Support	/		Storage	Enclos...	Neutral	No	No
	Bathrooms	5	1	5	3	15	2.86%	3	Support	/		Individual	Enclos...	Sound ...	No	No
Personal/Quite Zone	Private quarters	8	1	8	6	48	9.14%	3	Personal	/		Individual	Enclos...	Sound ...	No	No
	Meditation Room	8	1	8	1	8	1.52%	3	Personal	/		Individual	Enclos...	Sound ...	No	Yes
	Medical Bay	10	2	20	1	20	3.81%	3	Personal	Support		Small groups (2-3)	Enclos...	Sound ...	No	No
Social Zone	Kitchen	2	6	12	1	12	2.29%	6	Social	/		Small groups (2-3)	Open	Neutral	No	No
	Dining Room	3	6	18	1	18	3.43%	6	Social	/		Large groups (4-6)	Open	Neutral	No	Yes
	Living Room	4	6	24	1	24	4.57%	6	Social	/		Large groups (4-6)	Open	Neutral	No	Yes
	Social Space	4	6	24	1	24	4.57%	6	Social	/		Large groups (4-6)	Open	Neutral	No	Yes
	Gym	8	6	48	1	48	9.14%	6	Social	/		Large groups (4-6)	Open	Neutral	No	No
Work Zone	Research Labs	10	4	40	2	80	15.24%	3	Work	/		Large groups (4-6)	Hybrid	Neutral	No	No
	Agricultural Lab	10	4	40	1	40	7.62%	3	Work	/		Large groups (4-6)	Hybrid	Neutral	No	No
	Command & Control	4	6	24	1	24	4.57%	3	Work	Support		Small groups (2-3)	Hybrid	Sound ...	No	Yes
	Radio Room	4	2	8	1	8	1.52%	3	Work	Support		Small groups (2-3)	Hybrid	Sound ...	No	No
TOTAL AREA				525												

Section

Proof of Concept

L-System

Fragment

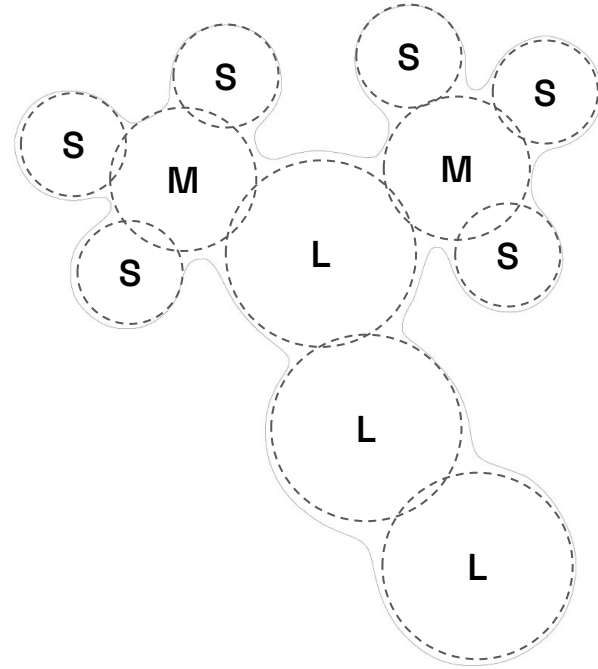
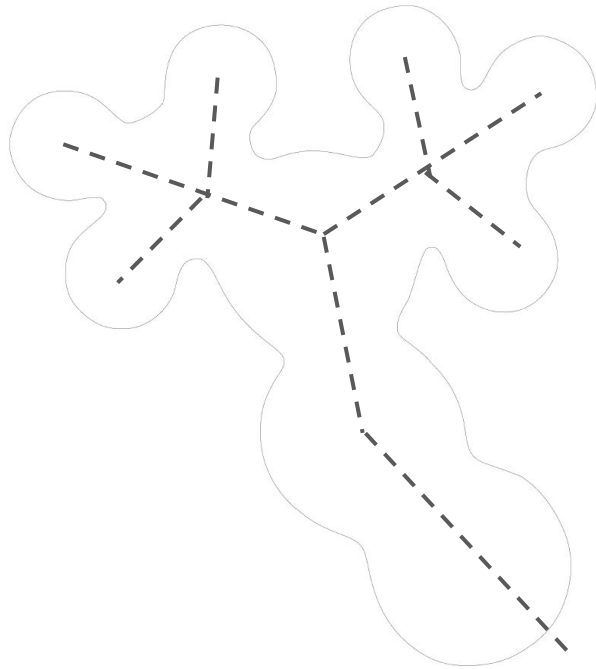

Bubble Diagram

Fragment

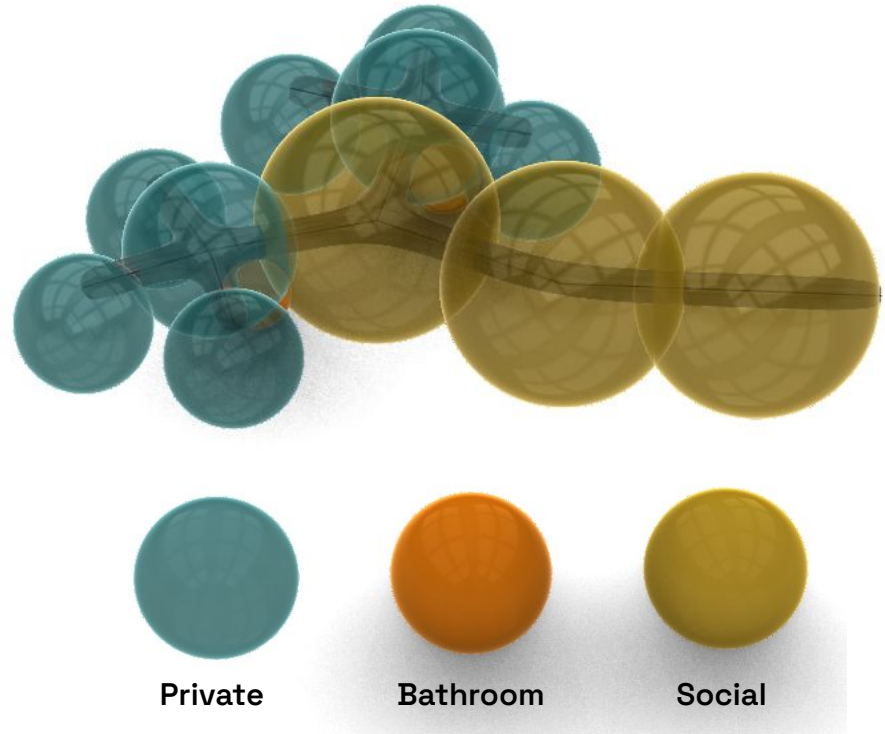
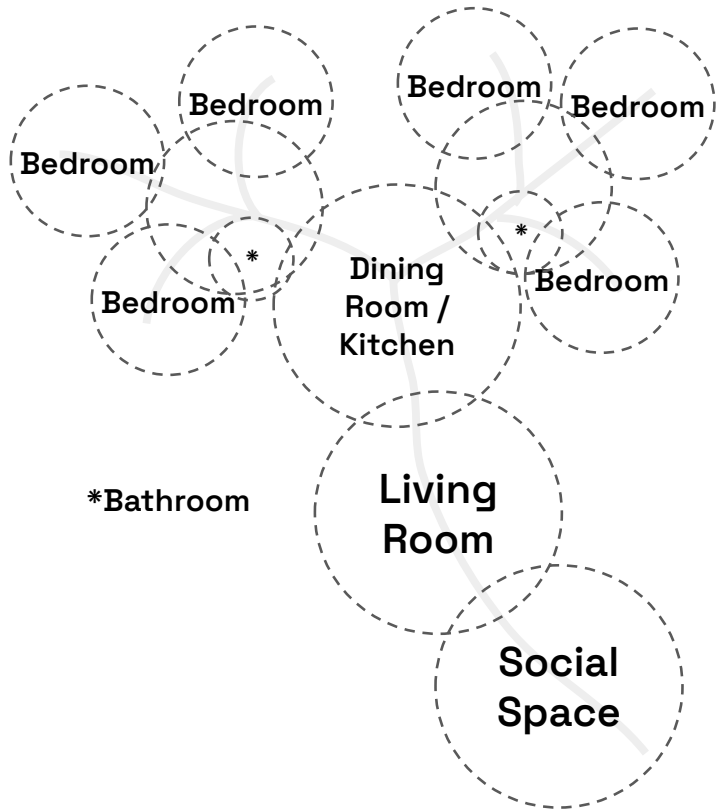

Bubble diagram → metaball volumes

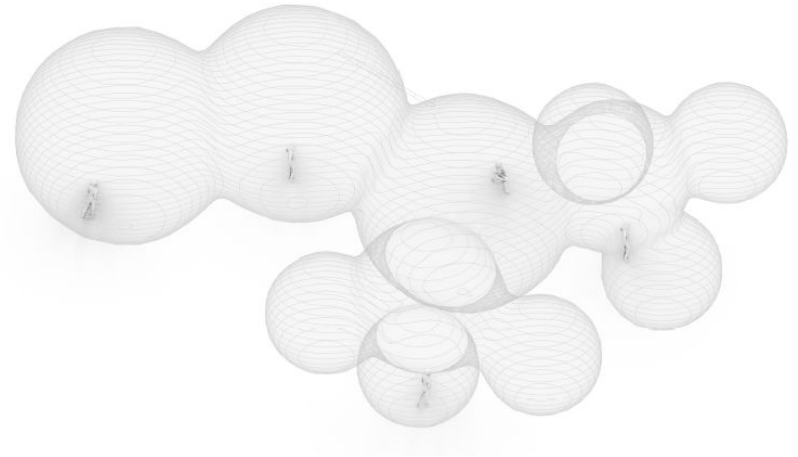
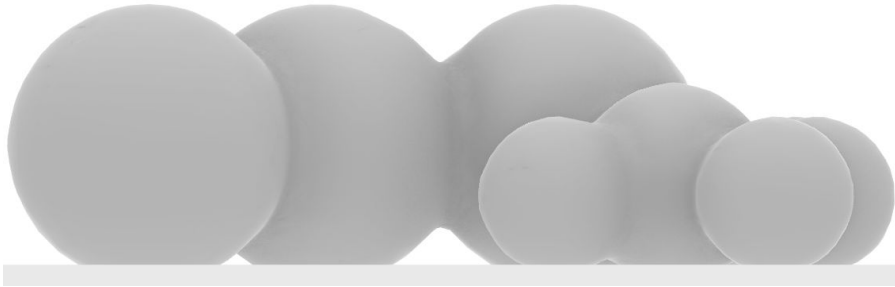

Metaball Adjustments

Increasing dynamic height
and metaball smoothing

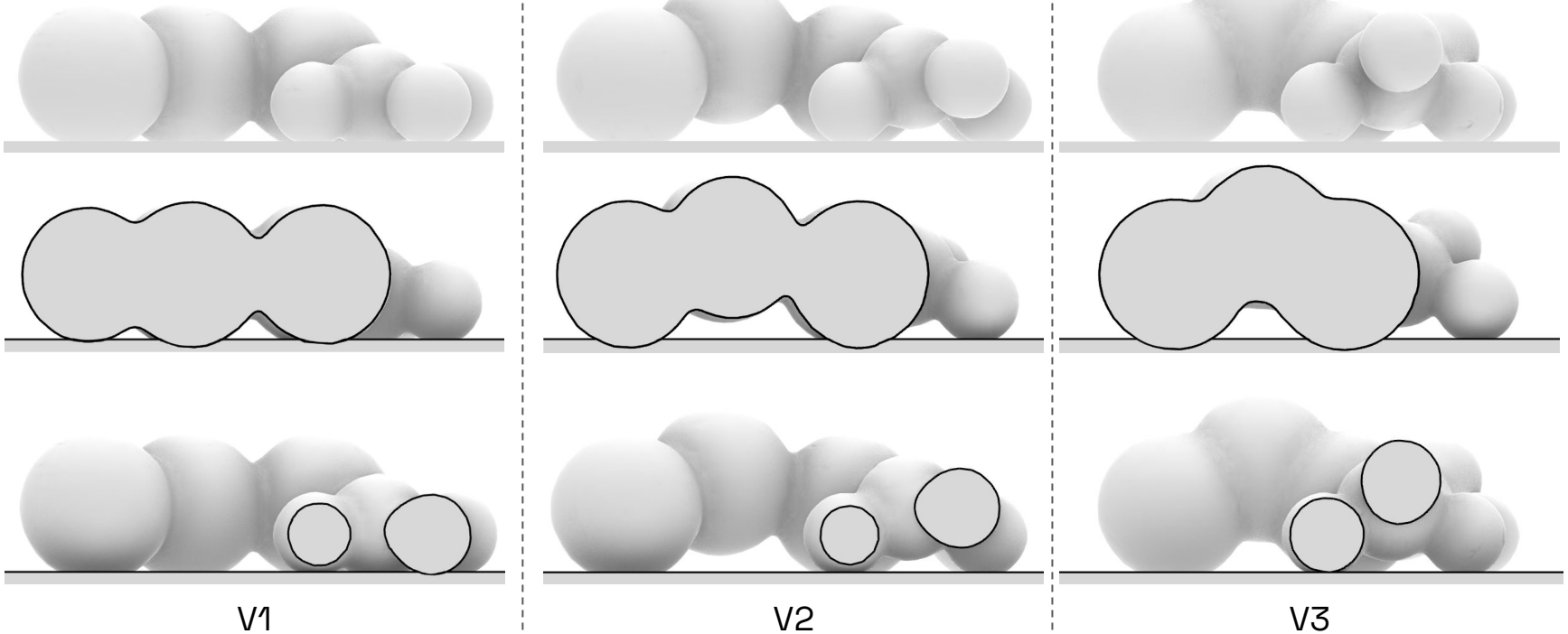

Metaball Adjustments

Fragment

V3

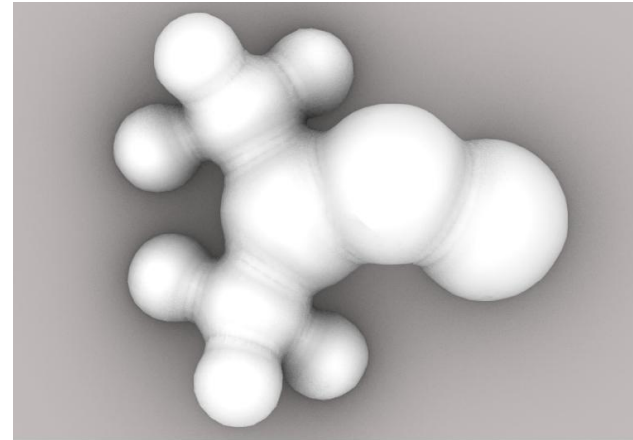
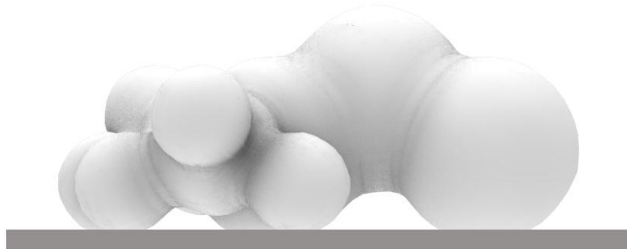
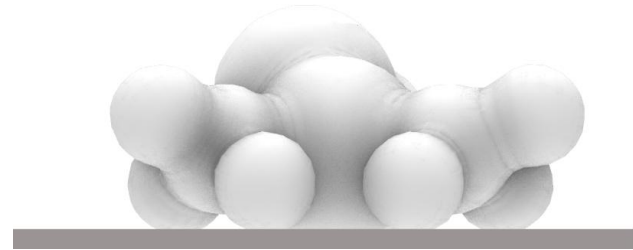
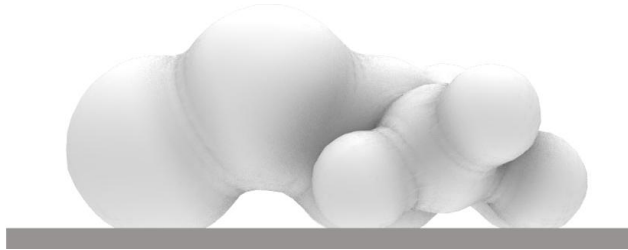

Radiation protection

- Lava tubes significantly reduce radiation exposure
- **54 cm of regolith** shielding is required for a safe habitat

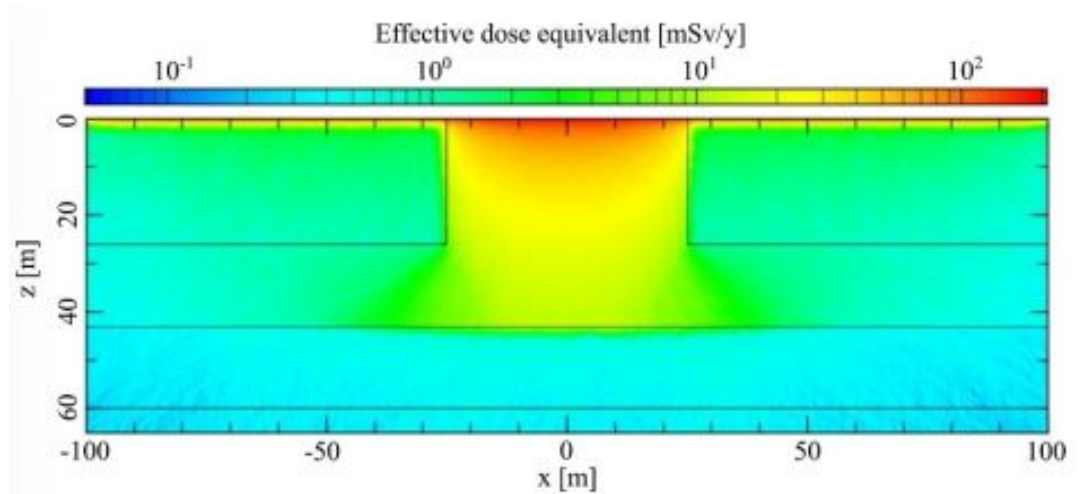

Simulation of effective radiation dose equivalent inside a lava tube. (from M. Naito et al. She et al., 2025)

https://moonshotplus.tudelft.nl/images/f/f4/1.13.1_RoboticsInstitute_FinalReport_JIP_2025.pdf

Design V1 - Force of Gravity

Max Compression
 $0.00869 < 9.250 \text{ kN/cm}^2$

Max Tension
 $0.00236 < 0.925$

Structure performs well in low gravity

Overengineered thanks to the thickness required for radiation protection

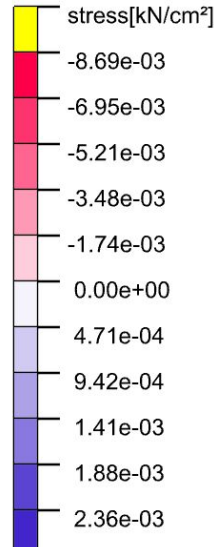
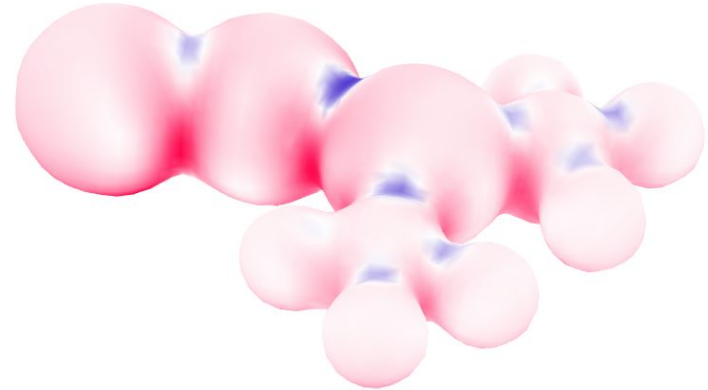

TABLE 4 Compression strength of samples solidified at different target temperatures.

Target temperature (°C)	1300	1400	1500
Compressive strength (MPa)	27.4 ± 2.6	118.2 ± 2.9	125.1 ± 18.4
Initial failure strength (MPa)	15.6 ± 7.0	65.5 ± 2.1	92.5 ± 16.3



Forces: Gravity

https://www.researchgate.net/publication/390602870_Melting_and_solidifying_behavior_of_lunar_regolith_simulant_under_a_vacuum_environment

Design V2 - Cantilevers

Raising the metaballs

→ More dynamic interior
facilitating jumpy lunar
movement

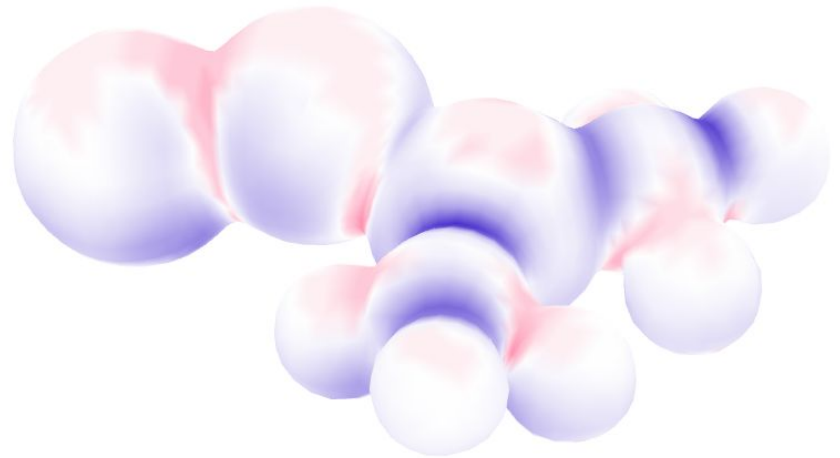
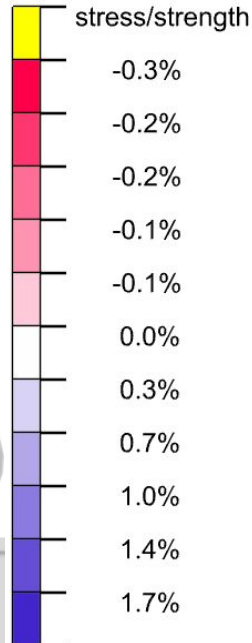
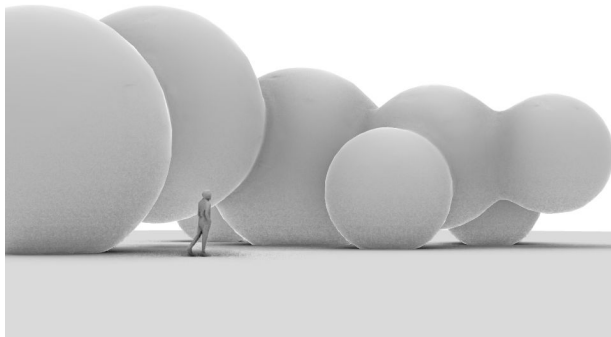

Forces: Gravity

Structural Justification

Fragment

Design V2 - Pressurised

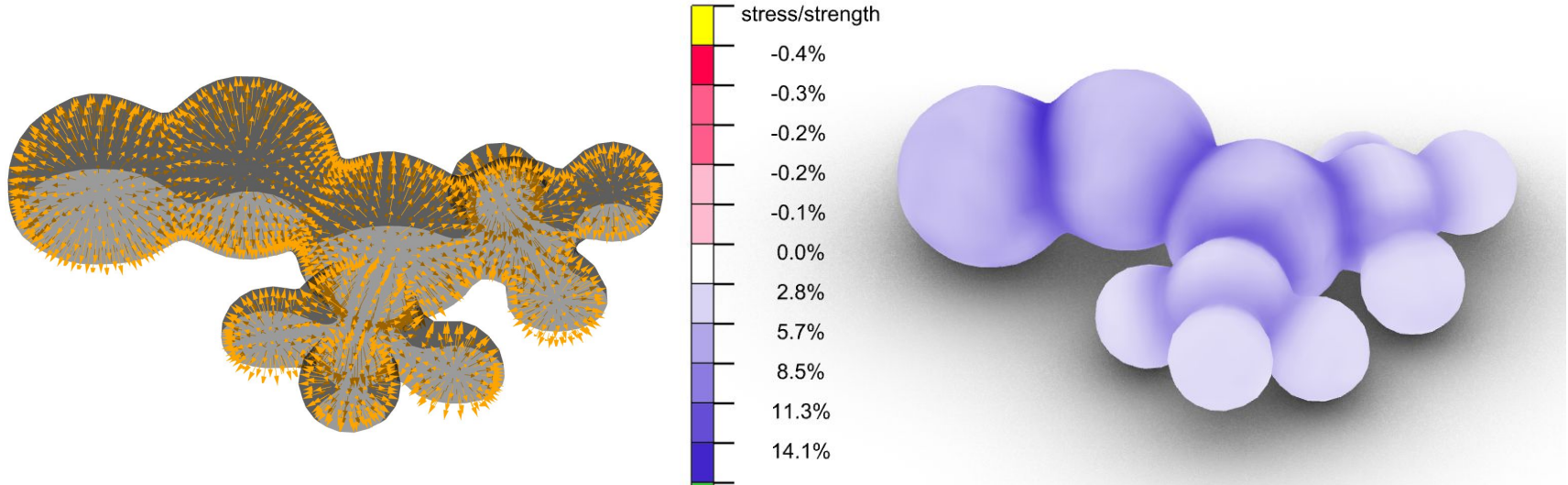

Air pressure pushes the shell out

Peak tension 1.7% → 14.1%

Forces: Pressure

Design V3 - Metaball smoothing

Metaballs are moved closer together and blended

→ More efficient load path to the ground

→ 'necks' are reduced

→ Reduce peak stress in the hotspots

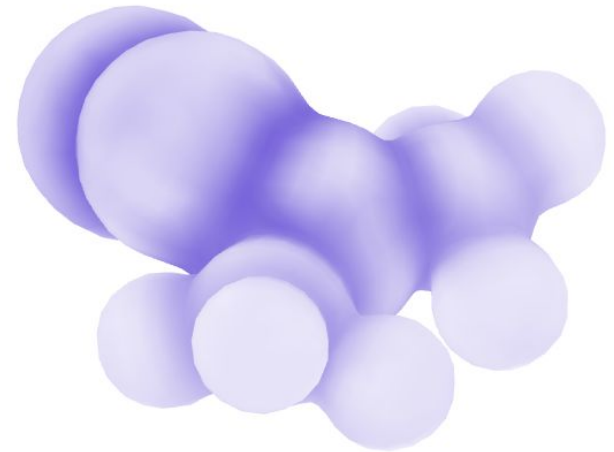
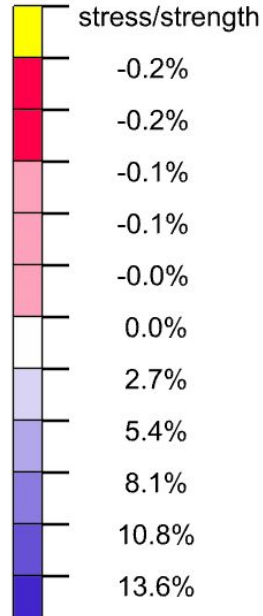

Forces: Gravity + Pressure

Window Type Exploration



Small



Large

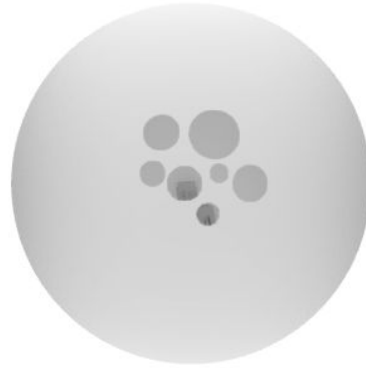

Mixed



Metaball

Window Type Exploration



Round

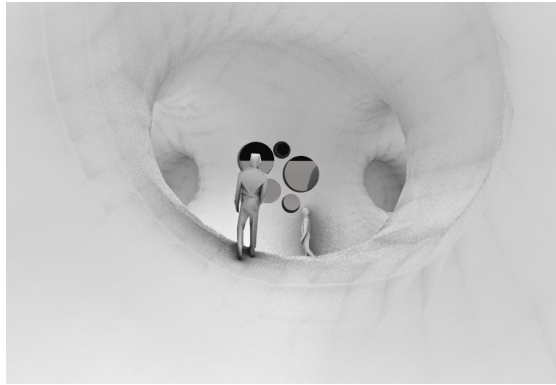

Mixed



Metaball

Porosity levels

	Function	Porosity Demand
	Private Quarters	Low-Medium
	Transition Space	No-Low
	Kitchen/dining room	High
	Social Space	Medium
	Living Room	High

- Dependent on function
- Private vs Public



Porosity

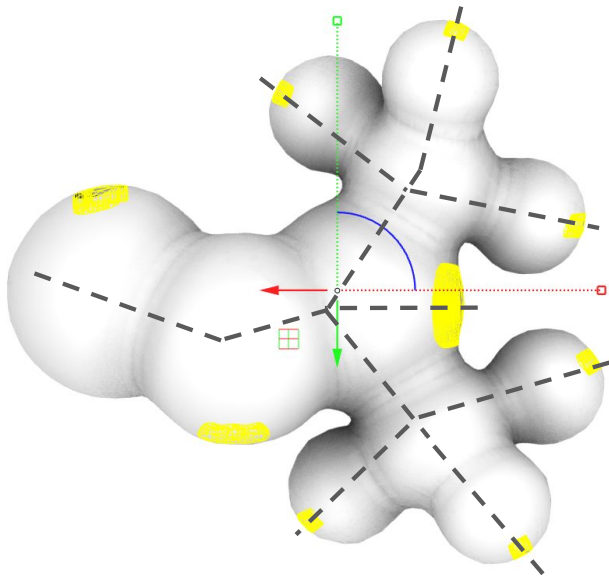

Windows generally
follow L-system axis

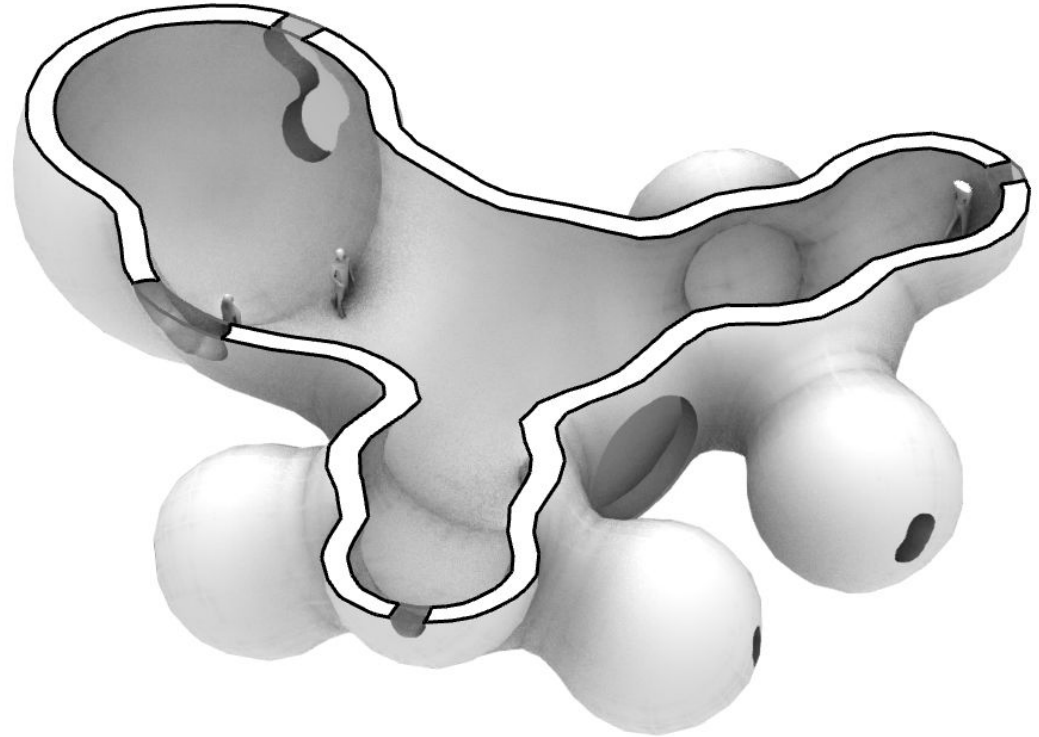

Porosity

Fragment

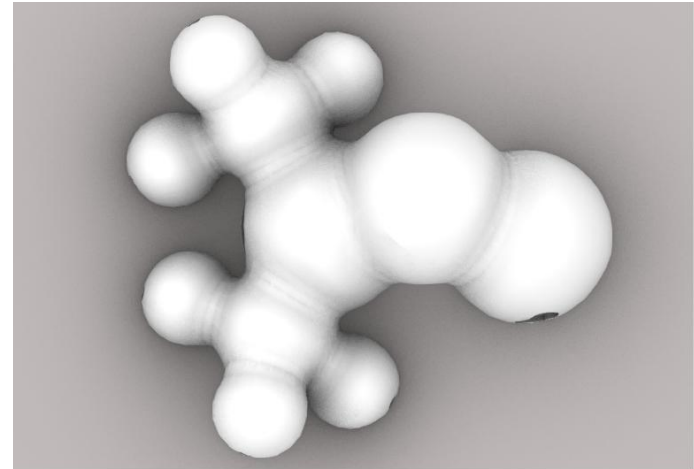
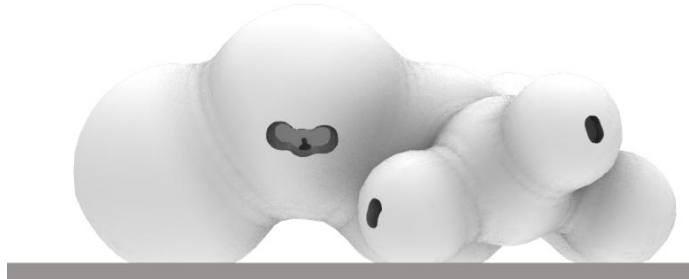



Interior - Lunar Playground

Fragment

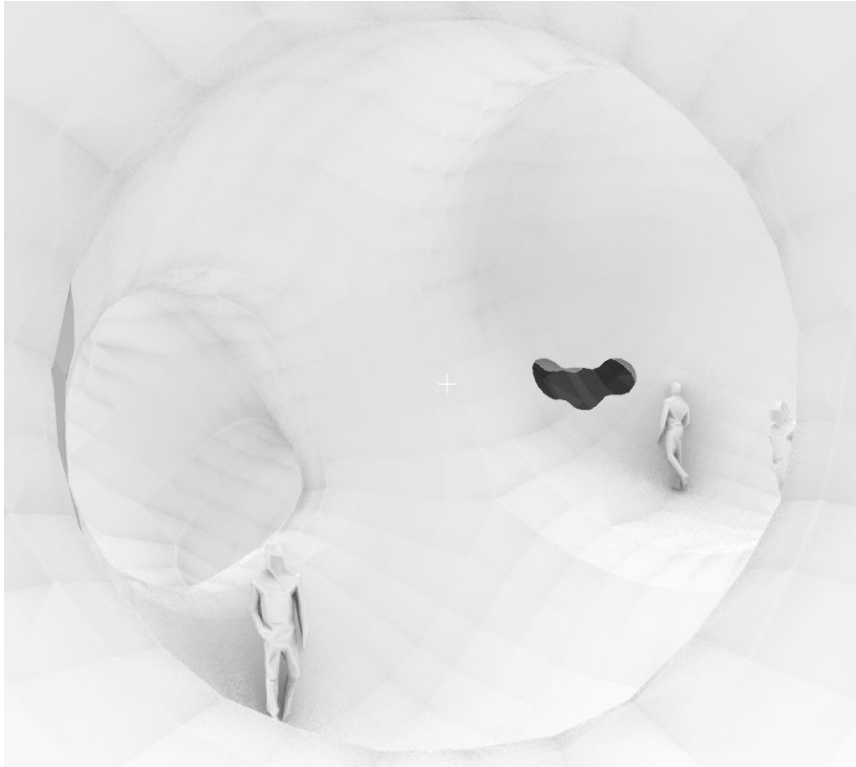

Circadian Lighting

Fragment

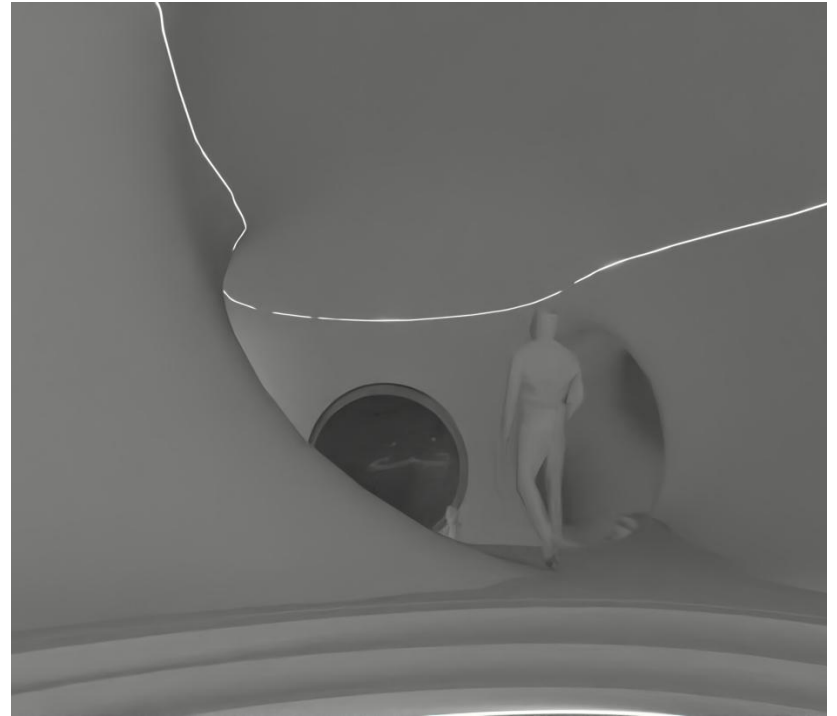

A black and white photograph of an astronaut in a full spacesuit standing on the surface of Mars. The astronaut is wearing a large backpack and is looking towards the camera. The background shows the undulating, dusty terrain of Mars under a dark sky. A white horizontal line is positioned below the word 'SECTION' and above the word 'Conclusion'.

SECTION

Conclusion

Design Steps

1. L-system
2. Bubble diagram
3. Metaballs
4. Metaball structure optimization
5. Porosity
6. Integrated Circadian Lighting



Checklist

- Non-monotonous, dynamic spaces
- Separation between public & private spaces → ability to retreat
- Lighting comfort
- Acoustic comfort
- Thermal comfort
- Air quality

Next Steps

- Integrate plant life into the indoor climate system to help with life support, food production, waste stream management and air quality
- Show thermal massing, heat sinks and plant cooling to increase thermal comfort
- Integrate biophilic inspired acoustic pattern on the interior
- Integrate biophilic pattern for the exterior