

A photograph of an astronaut in a full space suit walking on the lunar surface. The astronaut is carrying a large backpack and is positioned in the lower-left corner of the frame. The background shows the desolate, rocky terrain of the Moon under a dark sky. The title text is overlaid on the image.

# The Hitchhiker's Guide

to the

# Moon

a **Mind & muscle** Approach  
to **Spatial Perception** in  
Long-term Lunar Habitation

## **The Hitchhiker's Guide to the Moon**

A Mind & Muscle Approach to Spatial Perception in Long-term Lunar Habitation

### **Master Thesis**

AR4ETA010

Extra-/ Terrestrial Architecture

2025-2026

### **Zhangze Shao**

6197167

### **Mentors**

Dr. Dipl.-Ing. H.H. (Henriette) Bier

Ir. F. Adema

PhD-Cand. Arwin Hidding



Delft University of Technology

Faculty of Architecture and the Built Environment

Track Architecture

# **Abstract**

As humanity transitions from temporary lunar cells to permanent colonization, the fundamental challenge of space architecture shifts from basic survival to mental well-being. While current space engineering prioritizes life support over the qualitative mental experience, this research instead proposes a mind-and-muscle framework for spatial perception in lunar habitation that specifically addresses the “Missing Plumb Line”, the chronic cognitive dizziness caused by the absence of Earth’s gravity vertical.

Based on human-centred design approach, this study investigates how to keep the mind strong as part of space resilience. This resilience is fostered through the implementation of ‘Visual and Muscle Anchors’—deliberate geometric visual and force cues that provide the brain with an artificial sense of orientation and verticality, preventing the spatial flips and illusions that are common in low gravity conditions.

The design utilizes the *Oblique Function* to replace traditional floor-wall hierarchies with sloped and continuous surfaces. These surfaces engage inhabitants through muscular tension, providing them with a constant sensory alternative for the plumb line. The volume is generated through computational design that follows Voronoi (divide the space in regions), Point Charge (influence of charge strength) and Gyroid (minimal distance) logics, which optimizes both structural integrity and sensory complexity. Finally, the structural realization of this environment employs 3D regolith printing with In-Situ Resource Utilization (ISRU).

More than designing the habitat itself, the project also aimed to indicate a guideline for lunar lifestyle, a consciousness that the built environment is more than physical entity but also users’ cognition.

### **Key words:**

Low-gravity, Visual cues, Spatial perception, Human-centred design, Robotic building, 3D printing, In-Situ Resource Utilization (ISRU)

# INDEX

- 1.0 Background
- 2.0 Problem Statement
- 3.0 Objective
- 4.0 Research Questions
- 5.0 Approach and Methodology
- 6.0 Design
- 7.0 Relevance
- 8.0 References
- 9.0 Reflection

# 1.0 BACKGROUND

## 1.1 Context

From 'surviving' to 'living': Now we landed on the Moon, then what?

Space engineering determines how to 'survive' in outer space. When it comes to habitation, would it be like in the spacecraft Orion -- Astronauts need to live in 9m<sup>3</sup> of habitat volume for 10 to 21 days for Artemis II mission. It seems bearable to live in such small area for 10 days, but what about longer missions?

The design of the Mir space station represented space architecture in Low Earth Orbit. By carefully design modular functions, the station achieved certain efficiency in survival and research. Architect Galina Balashova focused on the psychological well-being of crews on long-duration missions, by defining "up" and "down" with dark green carpet floor and white ceilings, but forced the crew to spend nearly all their time on housekeeping (Balashova, 1980).

As astronauts having trouble recognizing ceilings and floors, maybe the concept of "up" and "down" should not be defined in the first place.

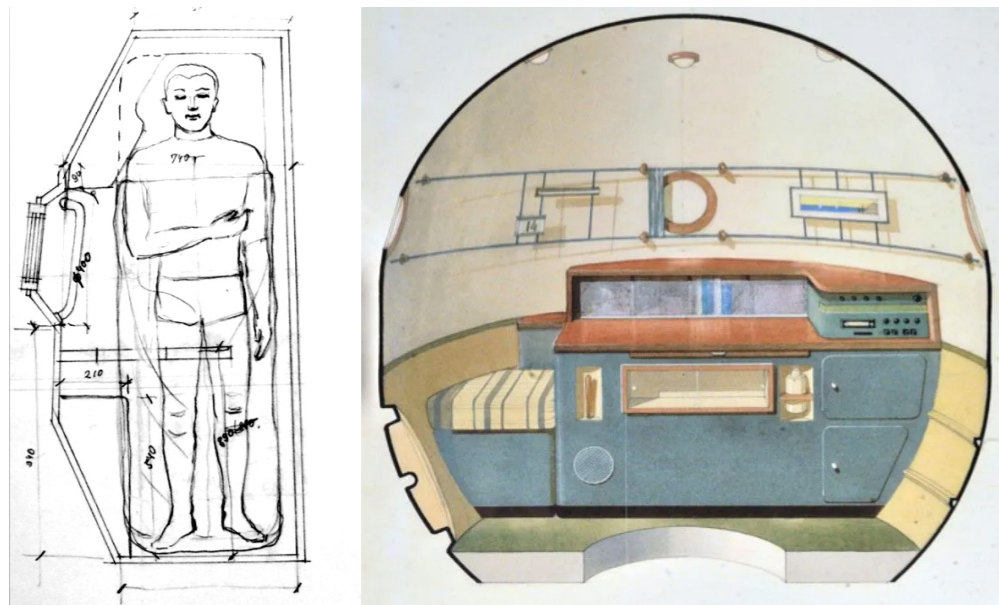

Fig.1.1 Sleeping pod  
[Galina Balashova, 1970-74]

# 2.0 PROBLEM STATEMENT

## 2.1 Main problem

**Missing of 'Plumb Line':** Cognitive disorder due to lack of gravity vertical

In order to define the problem, I looked back at the fundamental difference between earth and moon. Gravity is one of the major issues. Morfoisse (2024) investigates how gravity influences our brain's internal 'map' of three-dimensional space, and challenged traditional views with the idea that this 9.8G gravity is exclusive and fundamental to the earth that affects all interpretation in all sensory inputs.

As a result, Due to low gravity, the human vestibular system (in inner ear) becomes disordered, and the brain can no longer rely on gravity as an absolute reference for 'below' (Morfoisse et al., 2024). The Apollo 11, 12, and 14 astronauts also reported multiple serious visual misjudgements while walking on the lunar surface, that their perception of 'far' and 'close' failed to match with their own previous cognition on earth (NASA, 1971). Later research indicates that brain often defaults to mind and muscle vector: Down is simply measured by eyes or wherever your feet are pointing, regardless of the actual slope.

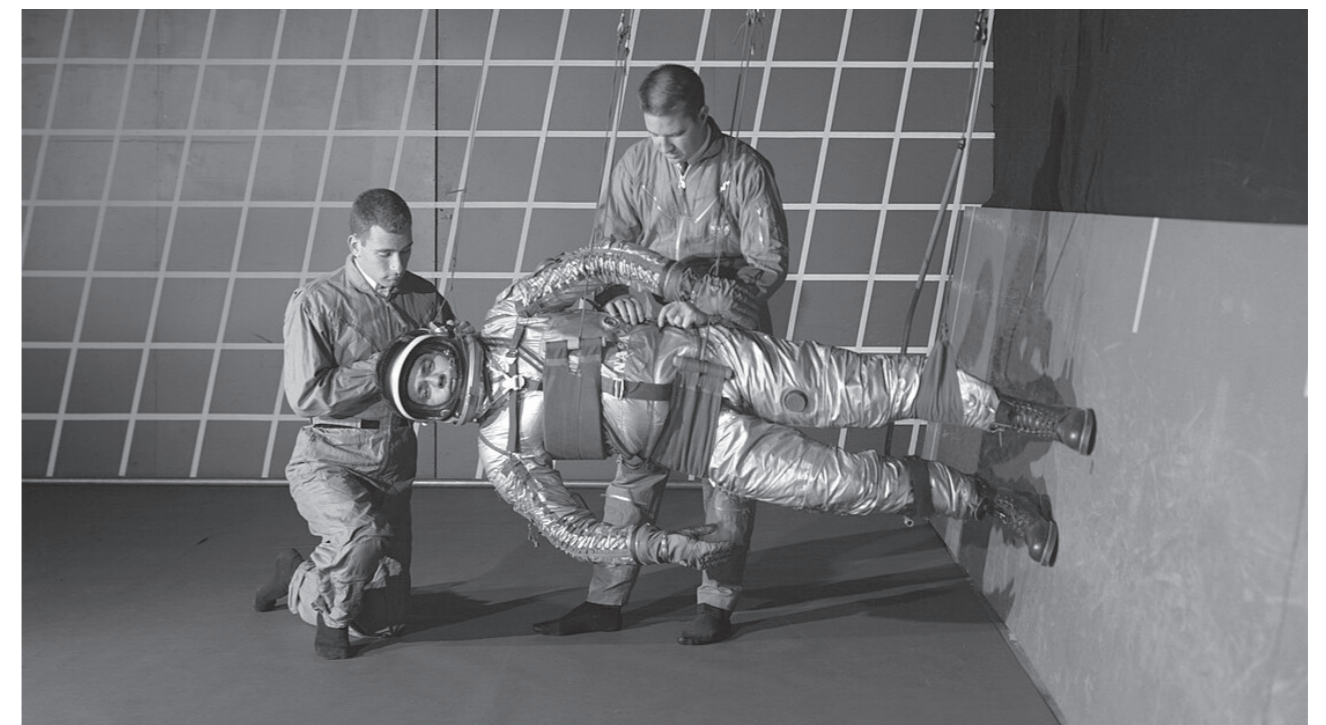

Fig 2.1: NASA testing moon gravity cognition, in a horizontal way [NASA, 1963]

# 3.0 OBJECTIVE

## 3.1 General Objective

Space exploration has always been fascinating, yet the reality is very different from what we've seen from Sci-fi movies. In 2001: Space Odyssey (1968), we are impressed by the spacecraft Discovery One, the Djinn chair, and the prediction of AI "HAL 9000" computer. The lasting impact goes beyond filmmaking, involved in Space Age Design, fashion industries and even the invention of iPad (Medium, 2018). People's lifestyle had already been changed without going to space. However, in reality, the design for lunar habitat is heavily technology driven, yet is necessary, to meet the minimal requirement of survival on the moon. But to actually live there, humans need more than just the basics.

### **Architectural objective: Space colonization**

**Indicating a guideline for about lunar lifestyle more than just survival, and bring technological consciousness where space can be determined more than merely volume but also minds**

Usually, we think of lunar base is a life-supporting machine. But in this guideline, moon habitat is also about expanding human consciousness into the outer space. On the Moon, the technology keeping you alive, and the goal of designed space is to make our minds work together so that we feel connected to our environment, rather than scared of the "vacuum" outside.

### **Technical objective: Space-resilience**

**Embodying cognition researches to spatial cues when designing lunar base, and being able to 3D print with ISRU technology in Robot building.**

# 4.0 RESEARCH QUESTIONS

## 4.1 Main Research Question

**How can architectural spatial design in extra terrestrial environment collaborate technology with perception, to deal with low gravity cognitive changes in movement and perception in maintaining mental well-being of future lunar habitants?**

## 4.2 Sub Research Questions

### **1. Premise: Physical survival challenge**

Design must be based on conscious research of physical ICE conditions in constructing and inhabiting lunar bases with ISRU (Oman C, M. et al., 2006)

### **2. Design: Sensing spaces**

Based on visual cues and movement study, how can the furniture, room, and lunar habitat dealing with sensory deprivation and monotony due to loss of gravity vertical?

### **3. Sequel: Mind over matter**

Between interactions of individuals and objects, how can the built space and architectural expressions cope with imbalance between privacy and social needs?

# 5.0 APPROACH & METHODOLOGIES

## 5.1 Site

**Location: Lunar South Pole.** On sunlit peak point of rim at Shackleton Crater

The location choice is mainly resource driven: Because of how the Moon tilts, the sun is always low on the horizon at the poles. Sunlight hits the rim of the crater but can never reach the bottom. At the Permanently Shadowed Regions (PSRs), water may exist because of the freezing temperature, along with other resources that are trapped by ice (NASA, 2022).

On the other hand, the perk received solar energy for 90% of the (earth) year. The advantage include solar energy, thermal radiation and the ability to see the earth (NASA, 2022). This combination of resources is why NASA and also other space agencies see this specific crater as the best place to build the first permanent lunar city.

Apart from the universal challenge of life-support, the specific challenge for this peak location at the rim is 10% time at low degree (average -53°C) and cosmic radiation (Leonard, 2022).

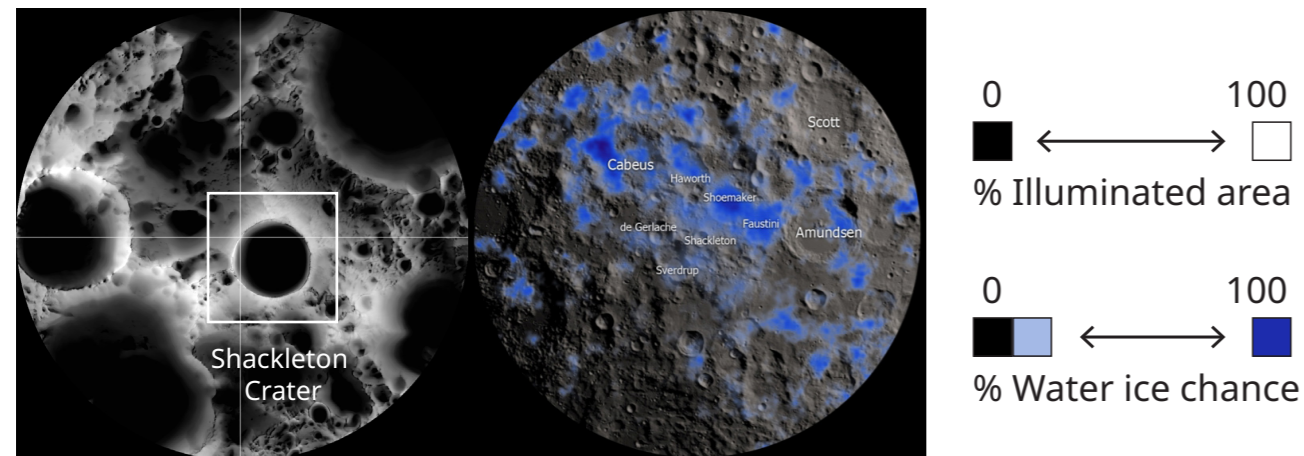

Fig 5.1.1: Lunar illuminated days [NASA, 2010]

Fig 5.1.2: South pole water ice [NASA, 2010]

## 5.2 Scope

### Strategic technology and timeline

#### ISRU extraction workflow: NASA's Plan.

According to NASA's research, ISRU in lunar south pole is primarily water ice trapped in PSRs. Extracting from water ice dirt, the resulting materials are breathable oxygen, gas and metallic by-products that can be used for 3D printing (Kleinhenz and Paz, 2020).

Apart from water ice, lunar rock consists of metal oxides. NASA also use extreme heat to strip oxygen from the minerals (NASA, 2015). The residue is a highly valuable mixture of raw metals prepared for lunar 3D printing in micro-scale, like electronics and hardware. While the leftover non-metallic waste can be mixed with lunar regolith as filaments for 3D printing in constructing habitats (NASA, 2015).

The regolith is already an in-situ resource on the Moon, but the binding material like polymer is a problem. Unlike earth, moon surface lacked carbon that can be extracted for organic materials. Nowadays, scientists are actively recycling binder from bio waste, as well as looking for inorganic substances inside regolith that can be used as alternatives, like using micro-ware melting and fusing powder materials to bond lunar dust (ESA, 2020; 2021).

However, diving deeper into this topic is not helpful for this thesis. It is time to look into the larger picture: After successful landings of multiple short-term lunar modules, this habitat is considered to be self-maintaining, lasting over a generation while developing to form their own space colonize culture. According to the space habitation plan by NASA, the context of this lunar base is settled in the 2080s, after humans have successfully harvest energy and material from PSRs of Shackleton Crater.

Therefore, there are three targets in construction of a moon base: Survivable, sustainable and operational (ESA, 2019), and this project is aimed at all three phases.

**Survivable:** Include fundamental protection of 3D print in-situ elements, design for swarm robots and investigation pods for autonomy installation

**Sustainable:** Accommodate researches in fabrication and preparation for future habitation

**Operational:** Expand the habitat for long-term and self-sufficient living and working on the moon

## Spatial design

### Programmes

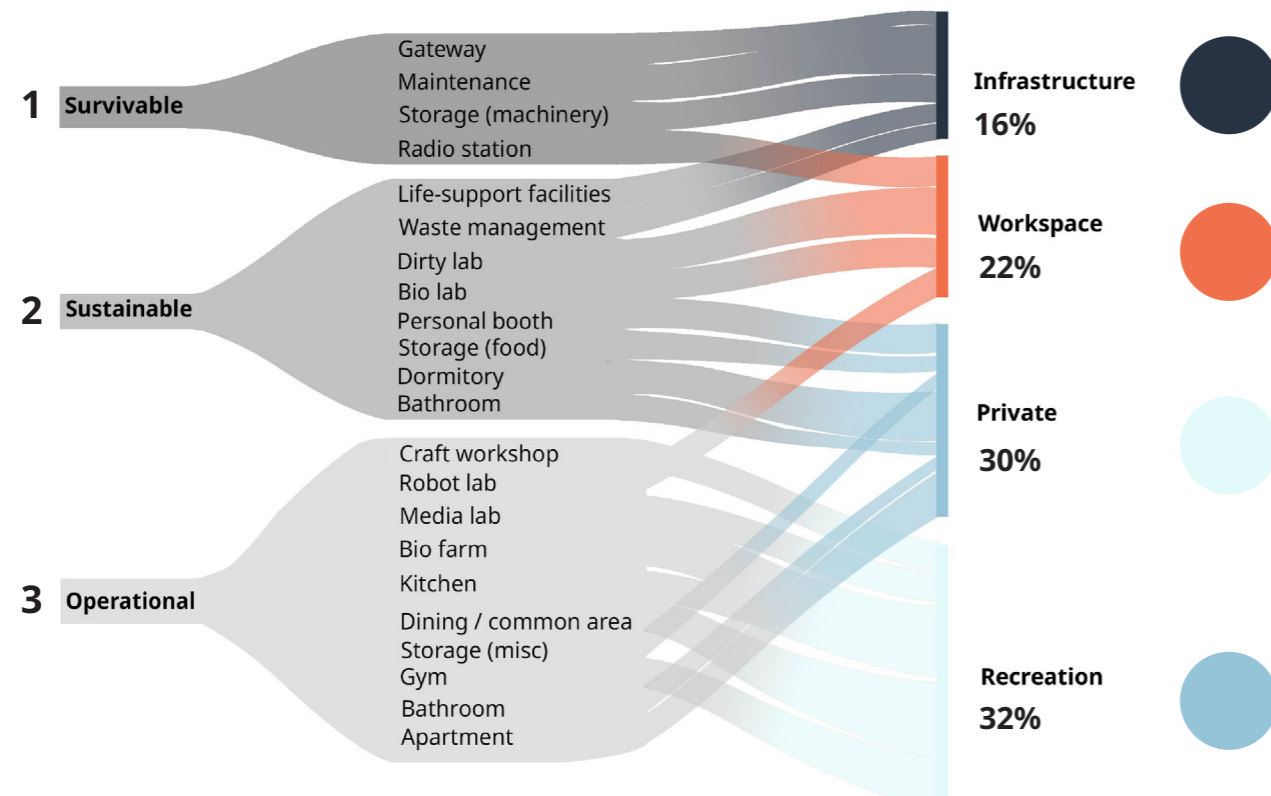

Fig 5.2.1: Programmes  
[author's own]

The visualization Categorize the expansion of a moon base: Survivable, sustainable and operational. Each phase then form spaces to required functionality required by ESA.

Moreover, these three phases also show the transition from the focus of Lunar time to internal time: At phase 1, lunar habitat requires mineral and radiation energy to survive, so programme functions directly relate to lunar time and condition more than habitant's well-being. At phase 2, programmes are focused on utilise moon resources for human self-sustain life-support. At phase 3, programmes only deals with lunar habitants' living quality, regardless of external lunar time but form an internal time that best suits the well-being of habitants.

## 5.3 Research Design

### How can we design without the 'plumb line'?

To improve cognition in a monotony environment where the brain gradually abandons the 'plumb line' of the earth, the research looks at what people rely on instead.

In 2016, an experiment titled *Visual Gravity Contributes to Subjective First-person Perspective*, investigated how the brain uses visual "gravity" cues to determine where you are located and from what direction you are looking at the world. The conclusion points out that gravity is a *multisensory anchor*. We don't just feel gravity with our inner ear; we 'see' it in the environment. When visual gravity conflicts with physical gravity, the brain can actually relocate the subjective first-person perspective, providing a scientific explanation for out-of-body sensations or the spatial flips experienced by astronauts in orbit (Pfeiffer et al., 2016).

Therefore, This research will employ a combination of literature study, case studies, workshops, as well as movement and visual studies to explore the logic behind human's physical receiving information and mental interpreting of space perception.

### Muscular perception in experiments

Experiments show the essence behind moonwalk is body's adaptation to 1/6G lunar gravity. The sense of space and 'down' is reclaimed by paying attention to keep body steady, as you need to know how you are going to fall based on the surface you touch.

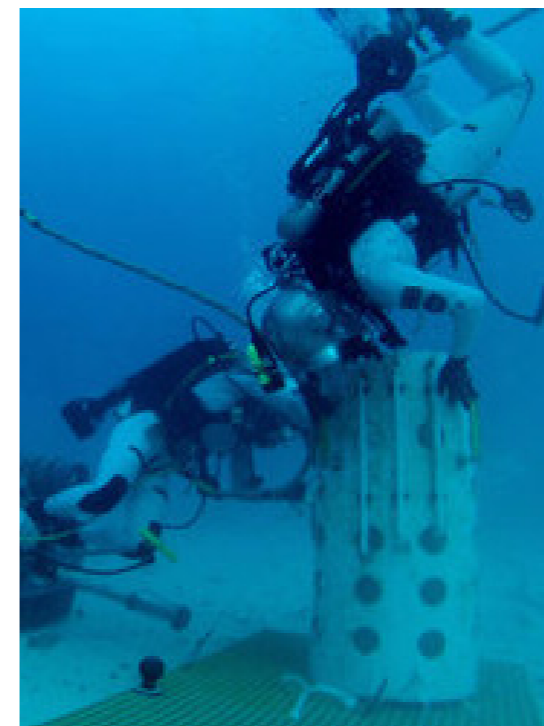

Fig 5.3.1: Moonwalk practice  
[David L. Akin, 2023. Video clip]



Fig 5.3.2: Moonwalk by Apollo 17 astronaut  
[NASA, 1972. Video clip]

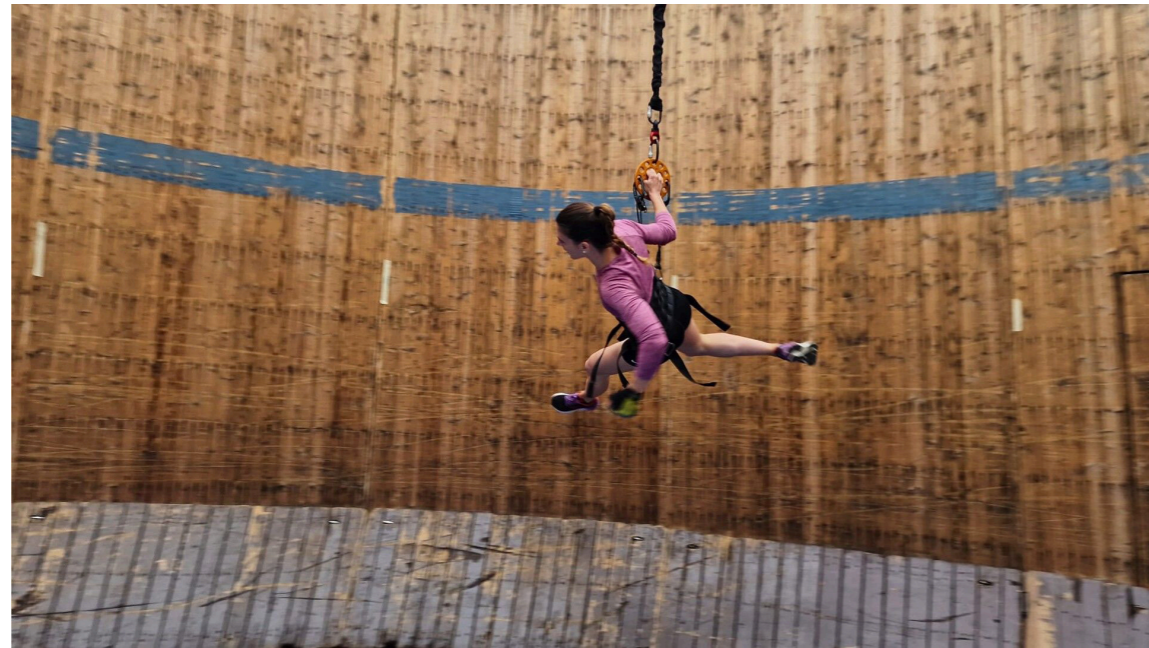

Fig 5.3.3: Simulate force on a sloped wall that counter-balance gravity  
[Prof. Alberto E. Minetti, 2024. Video clip]

## Muscular perception in architectural theory

Moreover, the movement study is based on theory of Oblique Function by Claude Parent (architect) and Paul Virilio (philosopher). The study examines the strength increase in muscular tension and compression in relation to human experience in different activities.

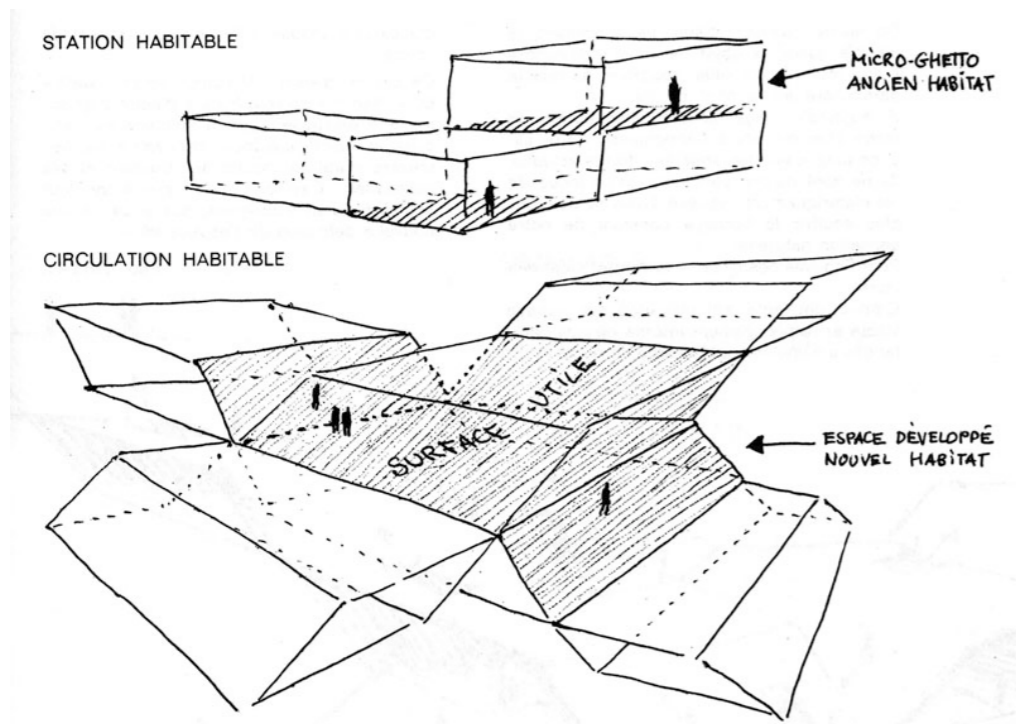

Fig 5.3.4: Oblique Function  
[Claude Parent and Paul Virilio, 1970]

## Visual perception in psychological research

The study of space perception are carried out primarily developed from visual cues, but also combining information from other senses in hearing, touch, and balance, under subject area of “space perception”.

To design without the “plumb line”, the study of human response to difference geometry is also conducted. In the research of Talmon, et.al. (2016), by simply ask the question “Does the shape of a room change how you feel?”, the researcher used Virtual Reality (VR) in experiment to prove geometry is a tool for the mind. This is helpful to determine rooms with different level of safety and functions.

Gibson (1979; 2014) also points out in ecological field that, the meaning of vision is that we don't just see geometry, we see what an object affords us. In his theory, visions can be translated in abstract patterns of *Fields of affordance*, which then is helpful in abstracting the geometry of vision that move beyond the unmesurable sight seen to sight encountered.

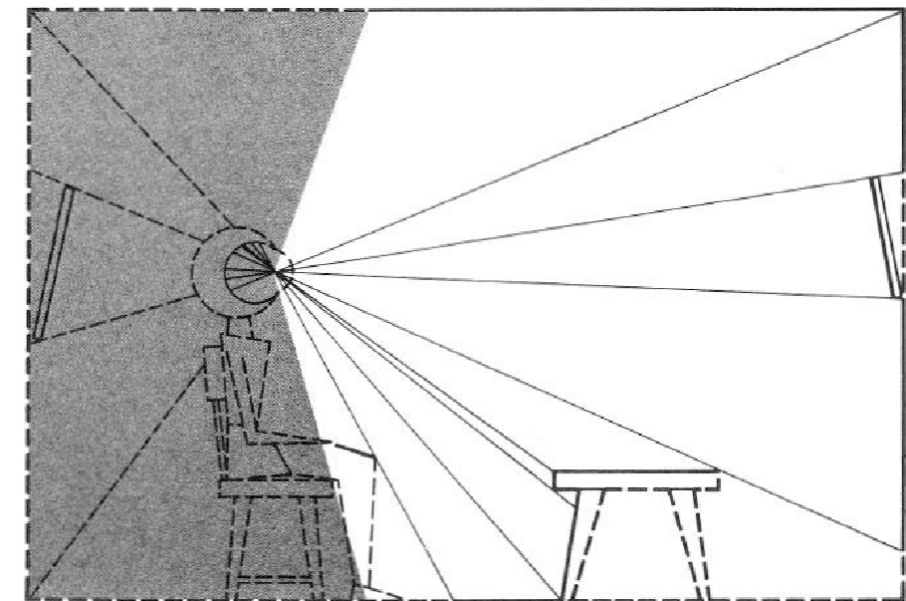

Fig 5.3.5: Figure from The Ecological Approach to Visual Perception  
[James. J. Gibson, 1979]

## Visual perception in architectural theory

Similar approaches are already taken place in architectural field, but without mentioning the name of ‘spatial perception’. Dated back to Bauhaus in 1930, the original diagram emerged from Bayer’s work and his interest in psychology and ergonomics. He argued that the traditional “picture on a wall” approach ignored the natural range of human sight. His theory and later 1935 exhibition shifted the definition of an exhibition from a collection of objects to a designed experience. By acknowledging the 180 vertical and 360 horizontal potential, he proposed that display surfaces should be angled to meet the eye perpendicularly, regardless of where they are placed in a room.

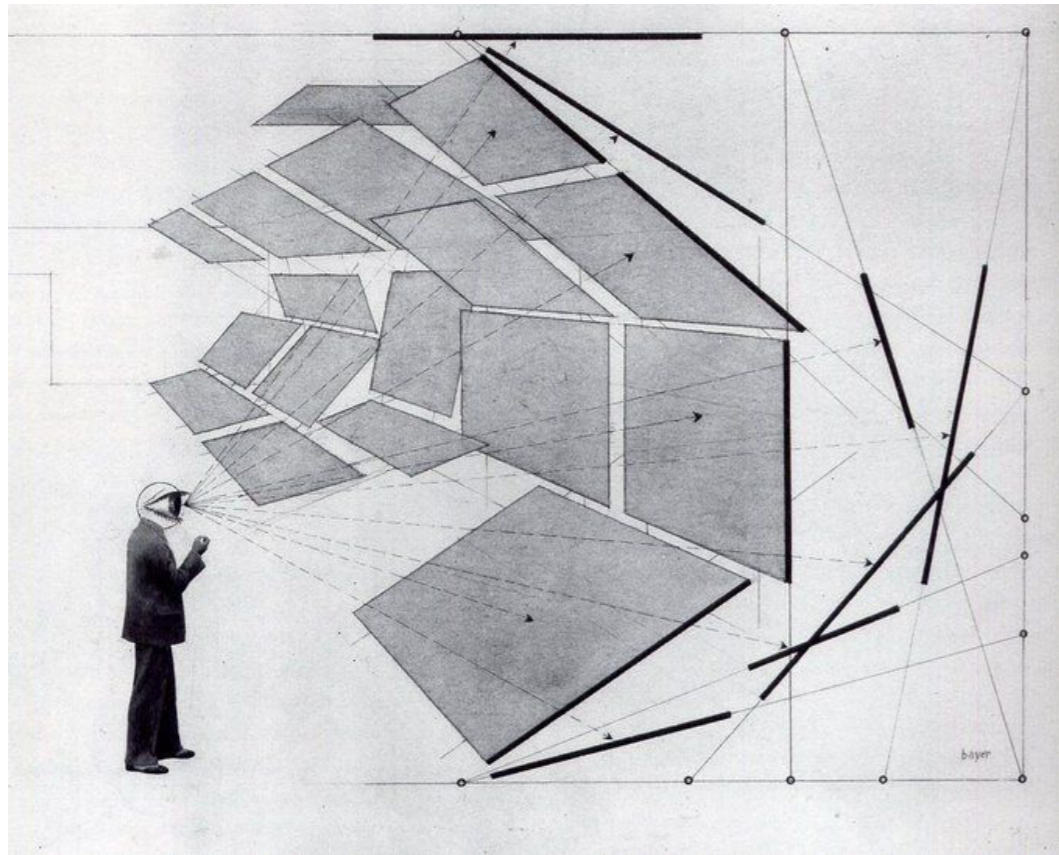

Fig 5.3.6: Diagram of the Extended Field of Vision  
[Herbert Bayer, 1930]

## Spatial attractors

By analysing current designs and changes in space station in an archaeological way, we can get an impression of what are contributing to muscular perception and to visual perception (Walsh, 2021).

### Visual anchor

- Lighting
- Monitors, indicator lights
- Rail (visual geometric protrusion)
- Signs, customization

### Strength anchor

- Positioning
- Working plane
- Buttons, panels
- Decking

Force anchors are charge points and visual anchors appear as a series of leading lines that draws the eye, balances the layout, and creates emotional harmony in an originally harsh-looking environment (fig 5.3.7 and 5.3.8)



Fig 5.3.7: Space station interior, factory new with few indicators  
[St P Walsh, 2021]

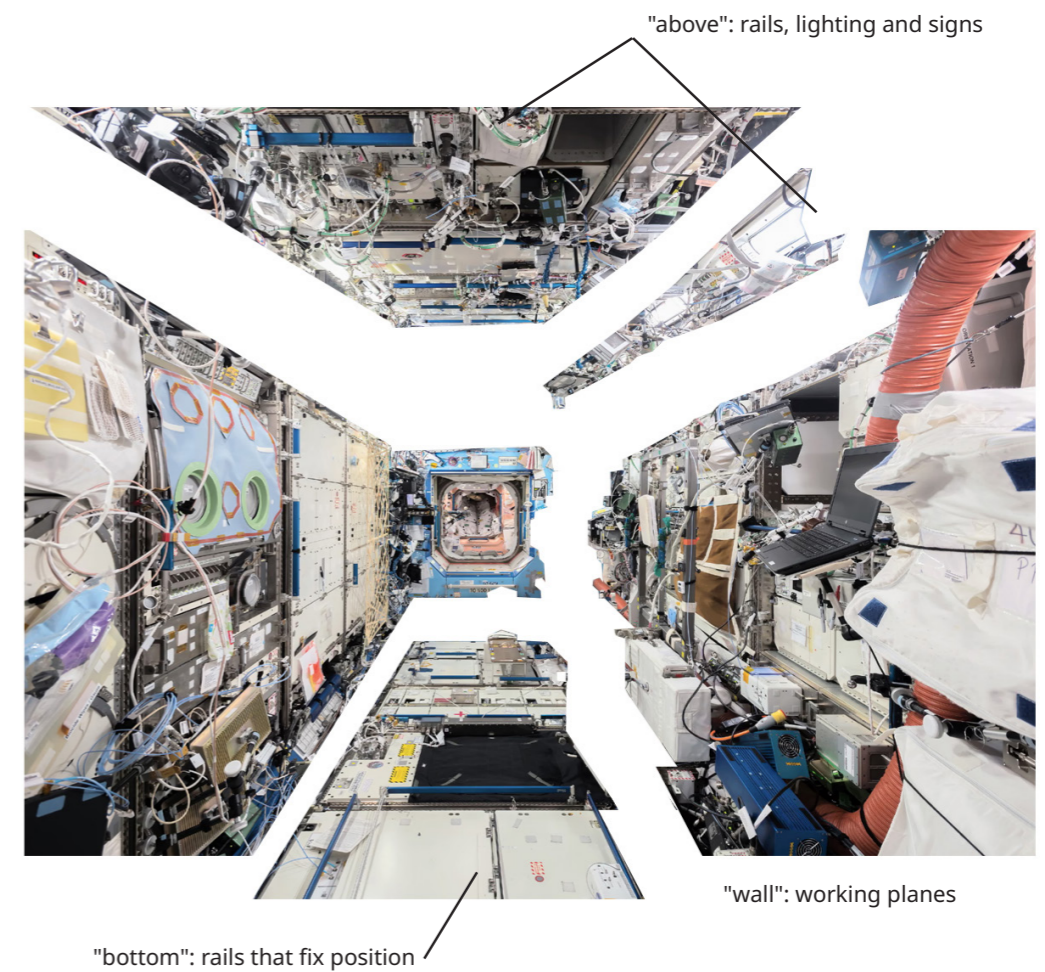

Fig 5.3.7: Exploded analysis of attractors  
[author's own]

# 5.4 Interpretation of anchors

People react differently according to ambient environment, but in an opposite way, the space can be defined for convenience so that users can quickly understand the different ambient by experiencing themselves in certain mode of vision and body position. Before defining the actual boundary and geometry, the correspond body position is analysed and divided into multiple anchors and attractors.

- External focus:** Reception, interaction of space and outcome
- Internal focus:** Pay attention to keep body steady
- Clear Zone:** Visually isovist-clear zone that allows interaction
- Supporting area:** Physically connecting area for muscle respond
- Visual anchor:** Horizontal extension of vision
- Force anchor:** Perpendicular force applied to surface

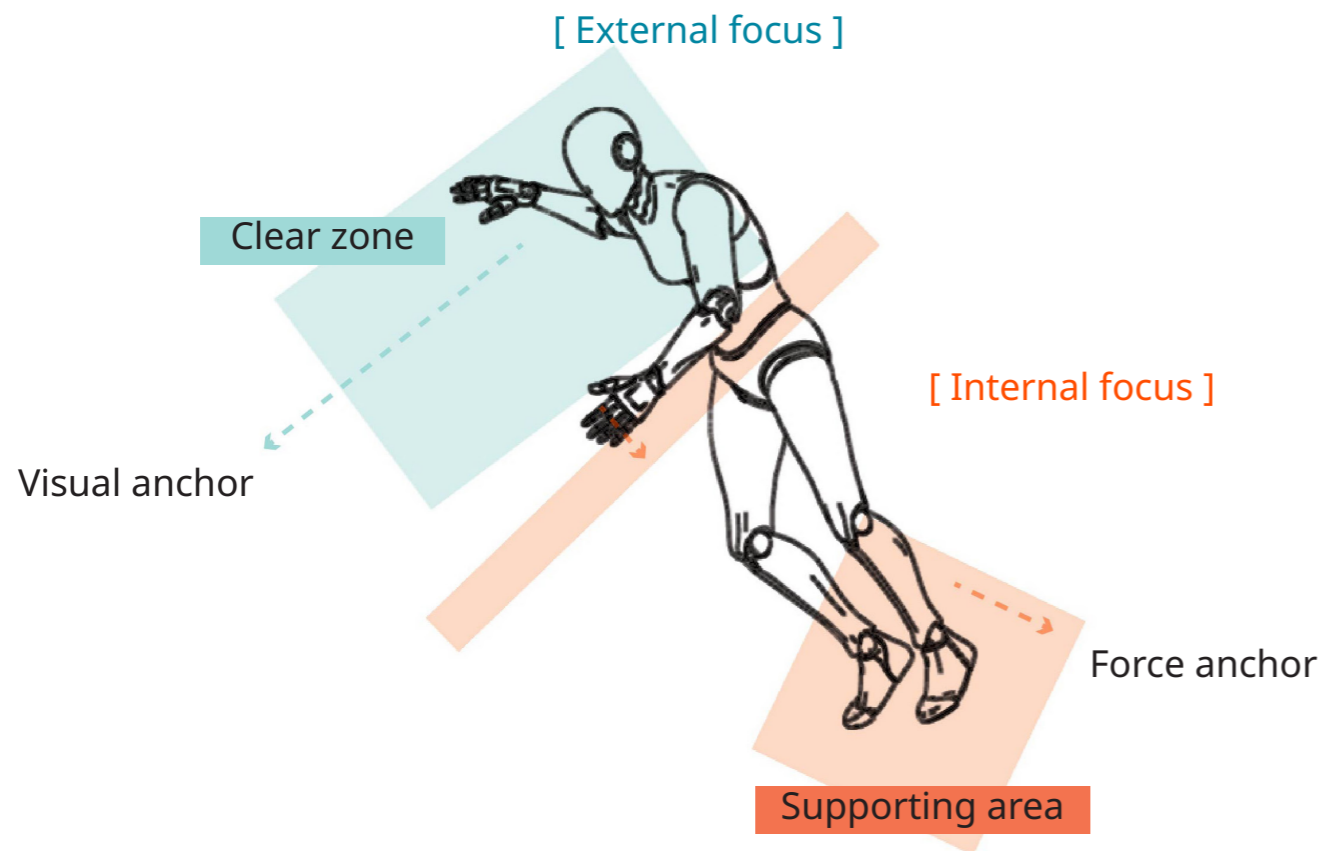

Fig 5.4.1: Analysis of visual anchor and force anchor

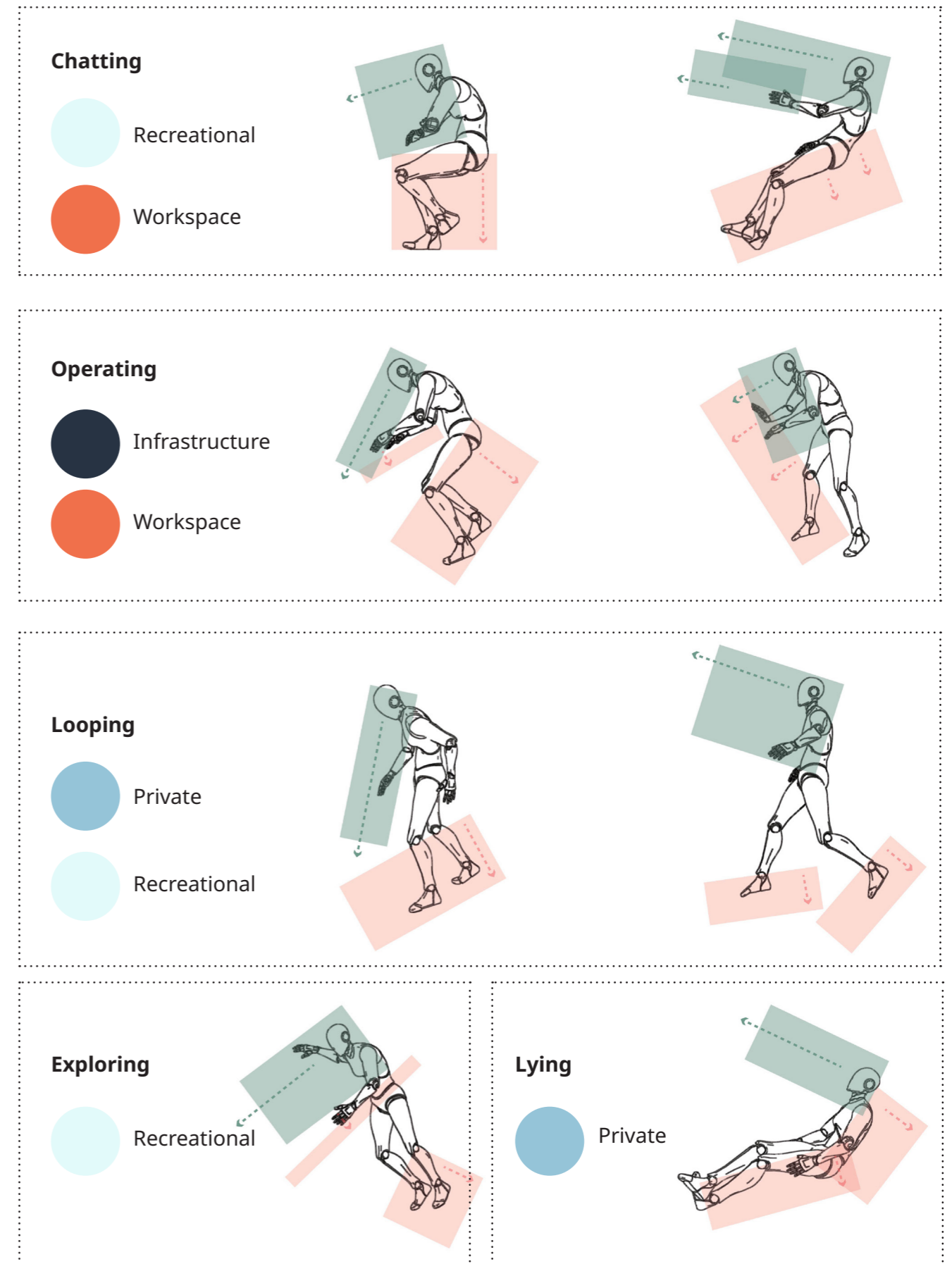

Fig 5.4.2: List of different modes in gravity interpretation

## 5.5 Case Studies

### Gyroid Climber San Francisco

Exploratorium

The structure is based on a “gyroid,” a complex infinitely connected periodic minimal surface that contains no straight lines. This creates a series of smooth, curving tunnels and surfaces that look like an optical illusion come to life. Frictions and tensions occur due to the irregular surfaces, along with diverse light and geometry



Fig 5.5.1: Gyroid climber

### Ku.Be House Frederiksberg

MVRDV + ADEPT

Instead of defining levels, architects use labyrinth, trap and net to move “upward”



Fig 5.5.2: Ku.Be House

### Jewish Museum Berlin & Denmark

Daniel Libeskind

In standard architecture, we expect 90-degree angles. Libeskind systematically eliminates them. Every room and corridor is composed of sharp, “stabbing” corners or wide, “stretching” walls. This forces the eye to constantly adjust to unpredictable perspectives.

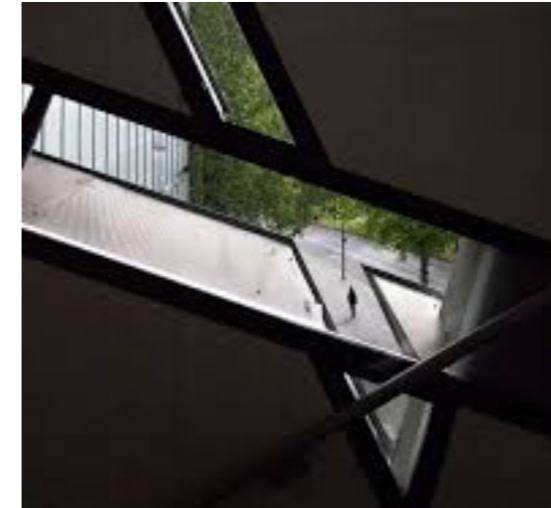

Fig 5.5.3: Jewish Museum Berlin

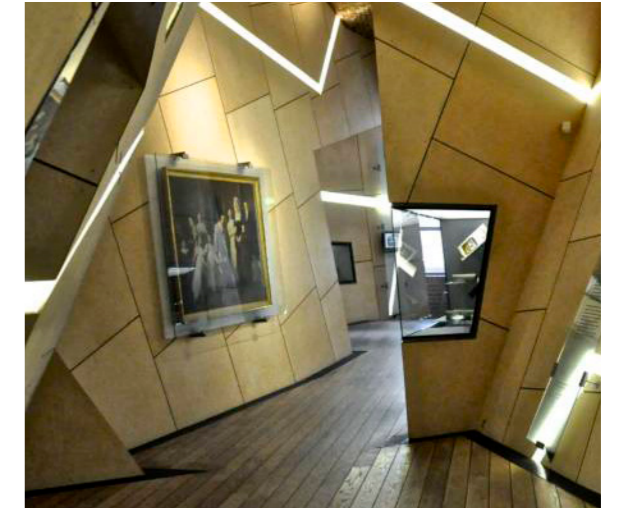

Fig 5.5.4: Jewish Museum Denmark

### Chapel of Sound Chengde

OPENarchitecture

Move further than slopes and geometry, this project communicate audiences with ambient created by layered patterns and material finish.



Fig 5.5.5: Chapel of Sound

# 6.0 DESIGN

## 6.1 Planing concept (macro)

### Independent gravity

Based on researches and analysis, Each programme can be influenced by lunar time and internal time, resulting in each programme having its own unique 'gravity'. Moreover, habitants' behaviour is influenced in designed gravity when coping with tasks that require certain focus of visual anchors and force anchors.

Further breaking down habitants' perception in low gravity environment, David (2023) points out in the underwater simulation tests that gravity sensation was amplified at different slopes. Thus, the planning concept is to distinguish gravity change when entering or exit to different modes.

Based on the degrees of gravity variation required for different functions, the zoning concept falls into three different level categories:

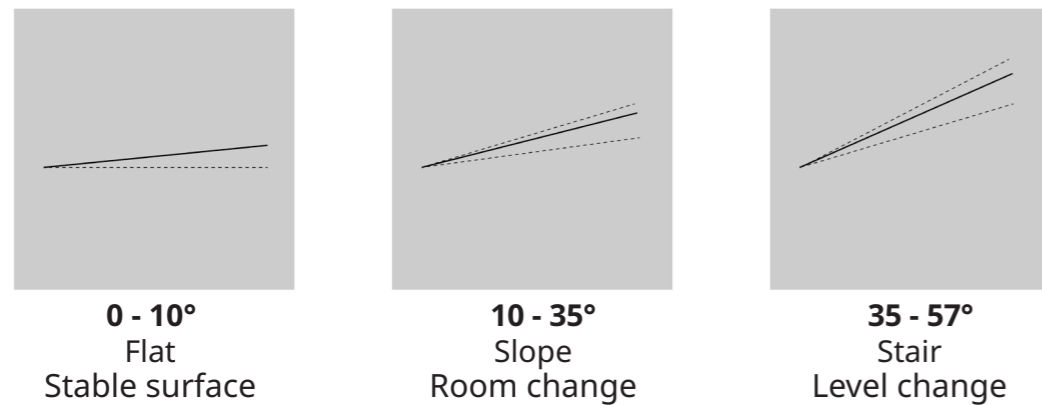

### Zoning in bounding box

According to gravity perception preferences, iterations are tested based on which category being the dominate gravity level.

In the mild sloping model, flat, stable surface is preferred, resulting in bounding box being flattened.

If the habitants have no preference in gravity change, a square bounding box is created for agents to explore relationships freely.

If the bounding box expands vertically, fewer programmes will stay on similar levels, with more level change expected.

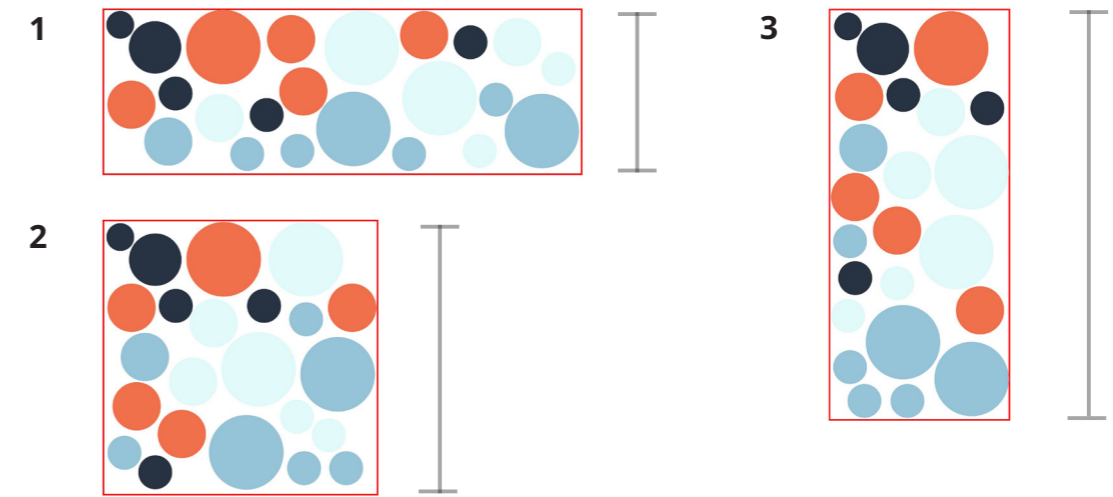
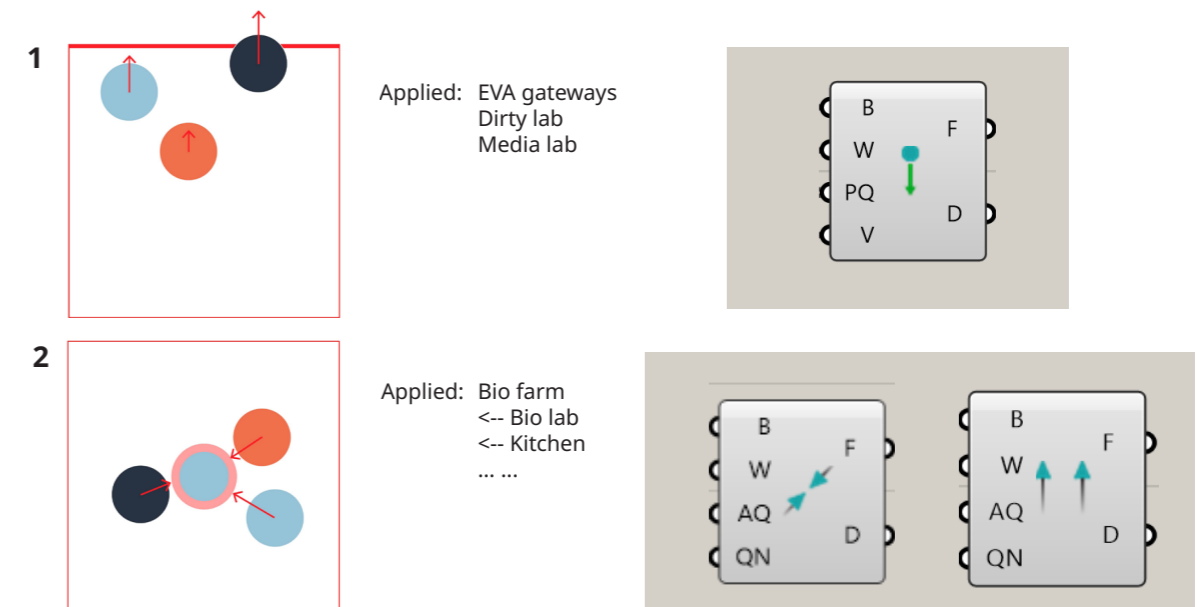
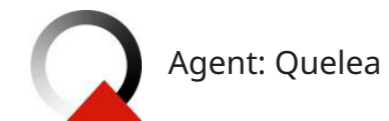

Fig 6.1.1: Bounding box iterations

### Agent rules

The behaviour of each function will affects its placement, and the behaviour includes:

1. **Pull.** Lunar time preference, strength pulled to lunar surface.
2. **Attraction.** Functions have logical or narrative relationships connect with each other. [**Align** applied at relations with linear narrative]
3. **Cohesion.** Programmes with shared internal time clustering together.
4. **Separate.** Functions that need privacy or equal distribution.



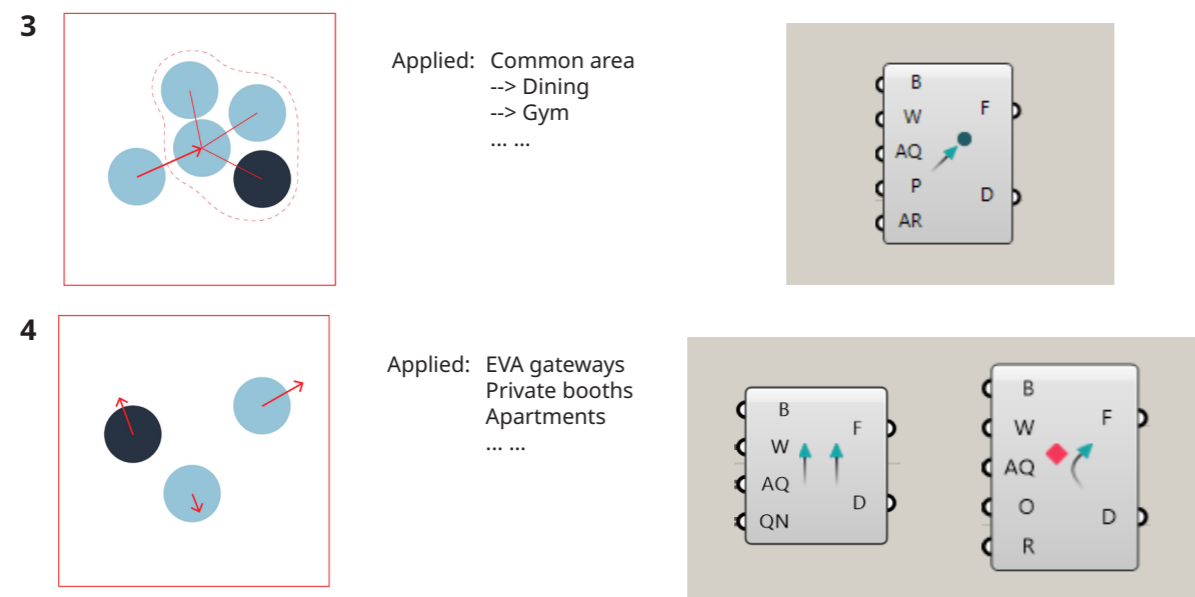

Fig 6.1.2: Agent rules

### 3D agent based modeling

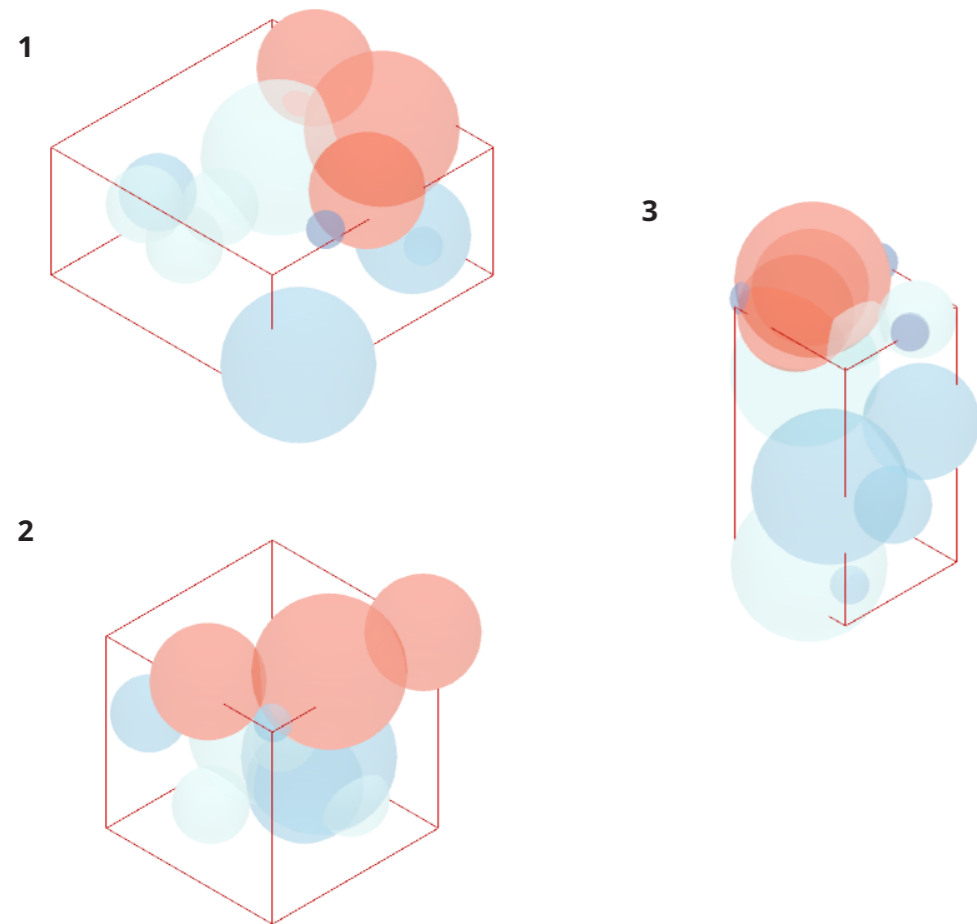
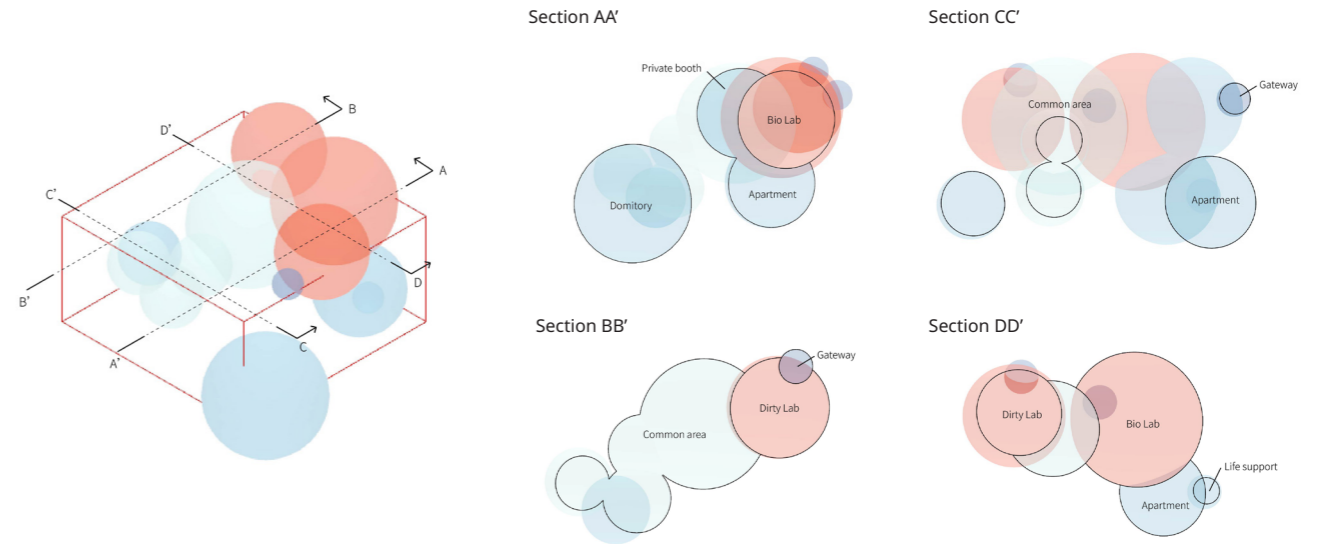

Fig 6.1.2: Clip from modeling animation

## 1 Evaluation of iterations

### Sloping: Bubble diagram



### Sloping: Circulation analysis

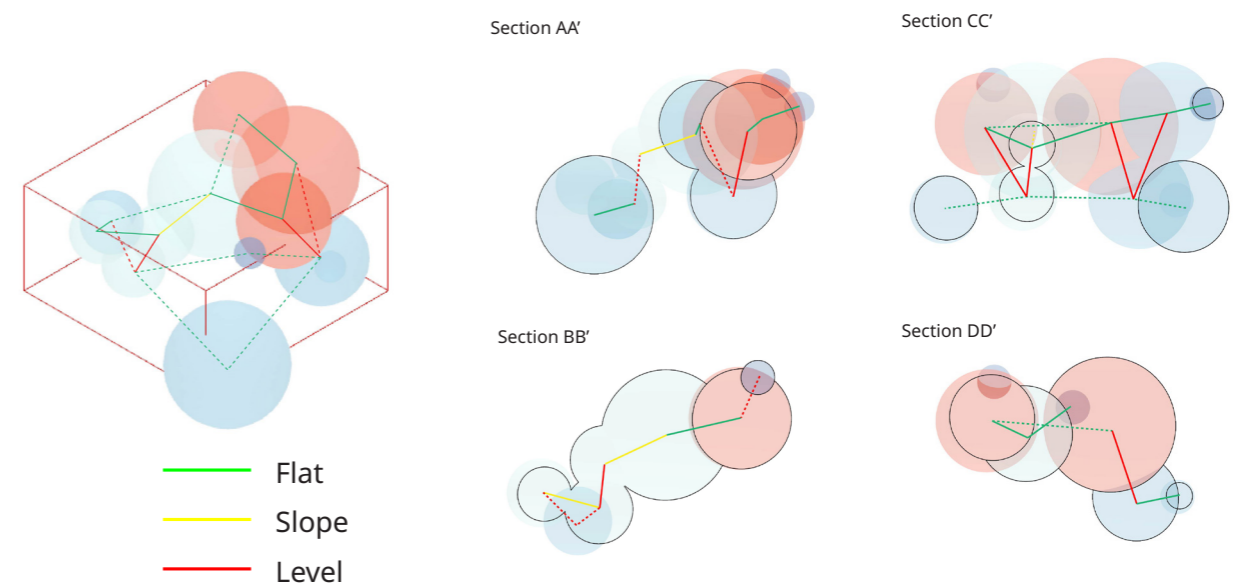

Fig 6.1.3: Outcome evaluation (1)

Because of larger flat surface area, functions that required lunar time distributed evenly on top surface, resulting related functions connect on similar levels, while unrelated functions zoning on another level. The hierarchy between lunar & internal time is clear. However, the inter-relationship between related functions is not enough to differentiate because the gradient is too subtle to notice a change in low gravity environment.

Moreover, flat distribution will cause more unwanted zones to be exposed under radiation, as the hierarchy is arbitrarily distinguished by lunar time or internal time without smooth transition.

## 2 Evaluation of iterations

### Neutral: Bubble diagram

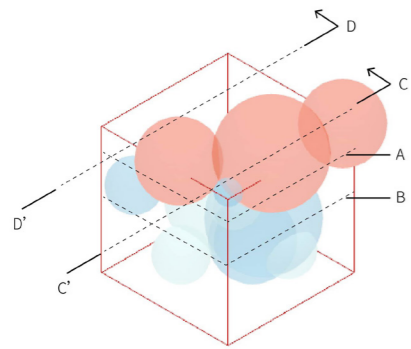

### Neutral: Circulation analysis

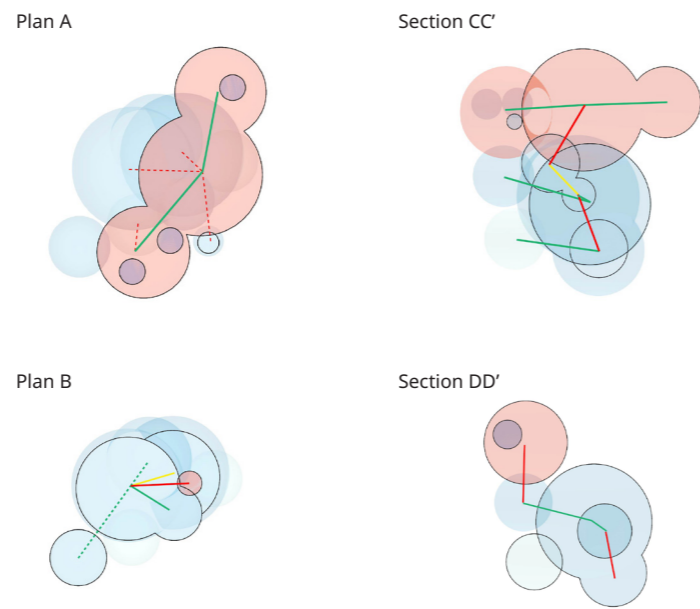
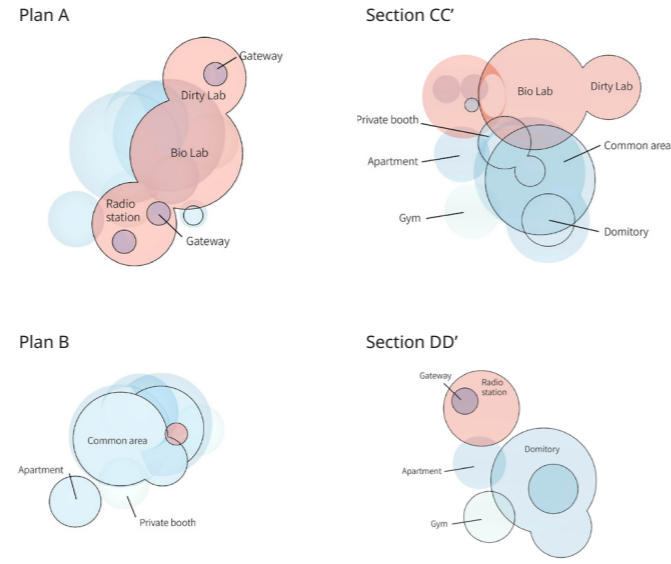
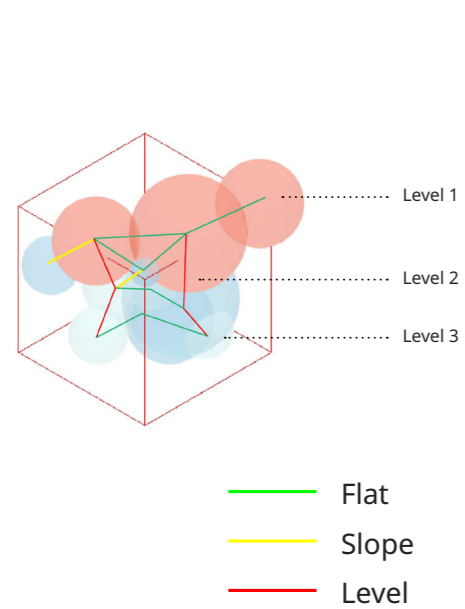

Fig 6.1.4: Outcome evaluation (2)

When no preference of bounding box is given, functions tend to gather together, and align equally under service functions and labs (survivable and sustainable functions that require lunar time). This results in a more compact zoning that minimize travel time.

However, equal levels cause less dynamic of the same function and segregation between layers. The static views, same-old routine and accumulating CO2 levels will harm habitants' mental well-being.

## 3 Evaluation of iterations

### Vertical: Bubble diagram

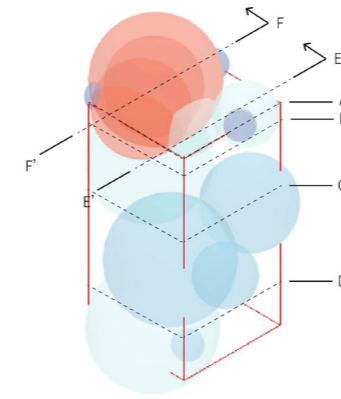

### Vertical: Circulation analysis

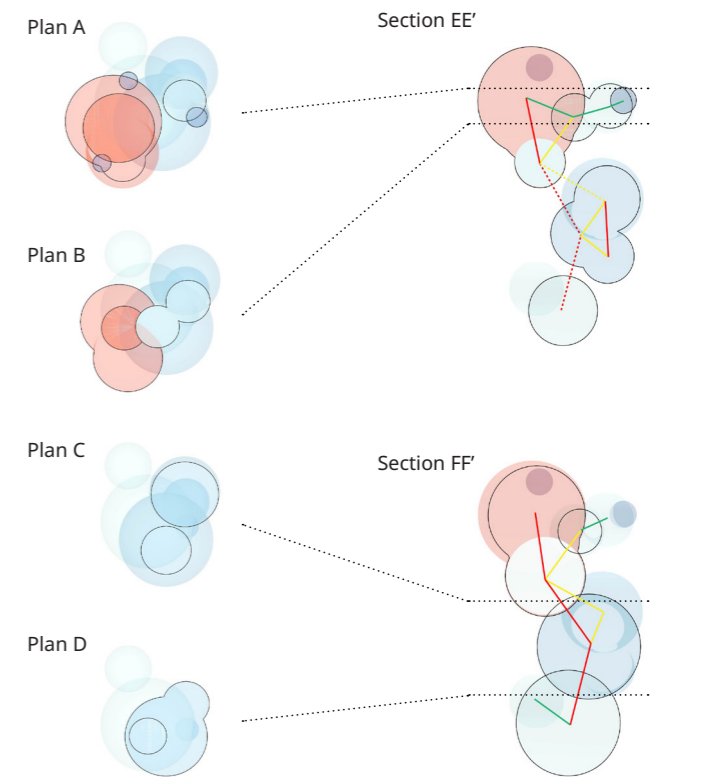
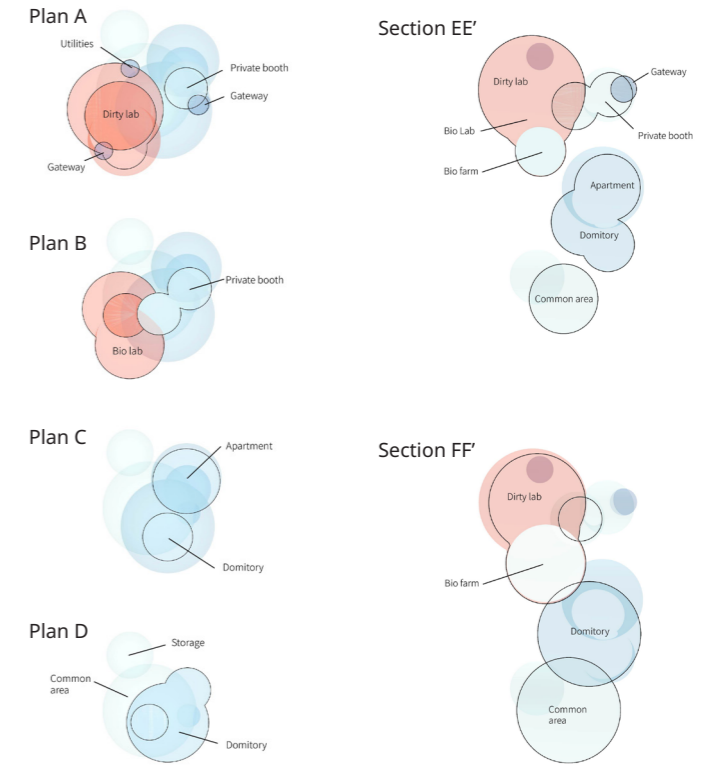
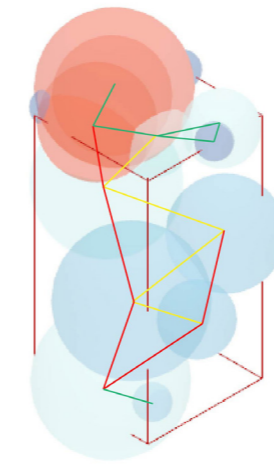

Fig 6.1.5: Outcome evaluation (3)

With fewer similar functions stay on the same level, this model shows rich variety of slope degrees and thus indicate more interrelationships. Operational functions that function with habitat's internal time is placed downwards and free from direct impact of space radiation.

# 6.2 Computational translation

This approach translates from non-standard impressions to measured attractors and vectors, contributing rooms with individual gravity.

## Why Voronoi

While bubble diagrams indicate size and gravity relationships, Voronoi not only helps to define wall (and floor) boundaries that independently to gravity direction, but also generates contacting surfaces between each rooms. With standing surface, working surface and wall surfaces defined, the bubble diagram can be translated to actual volumes with individual gravity.

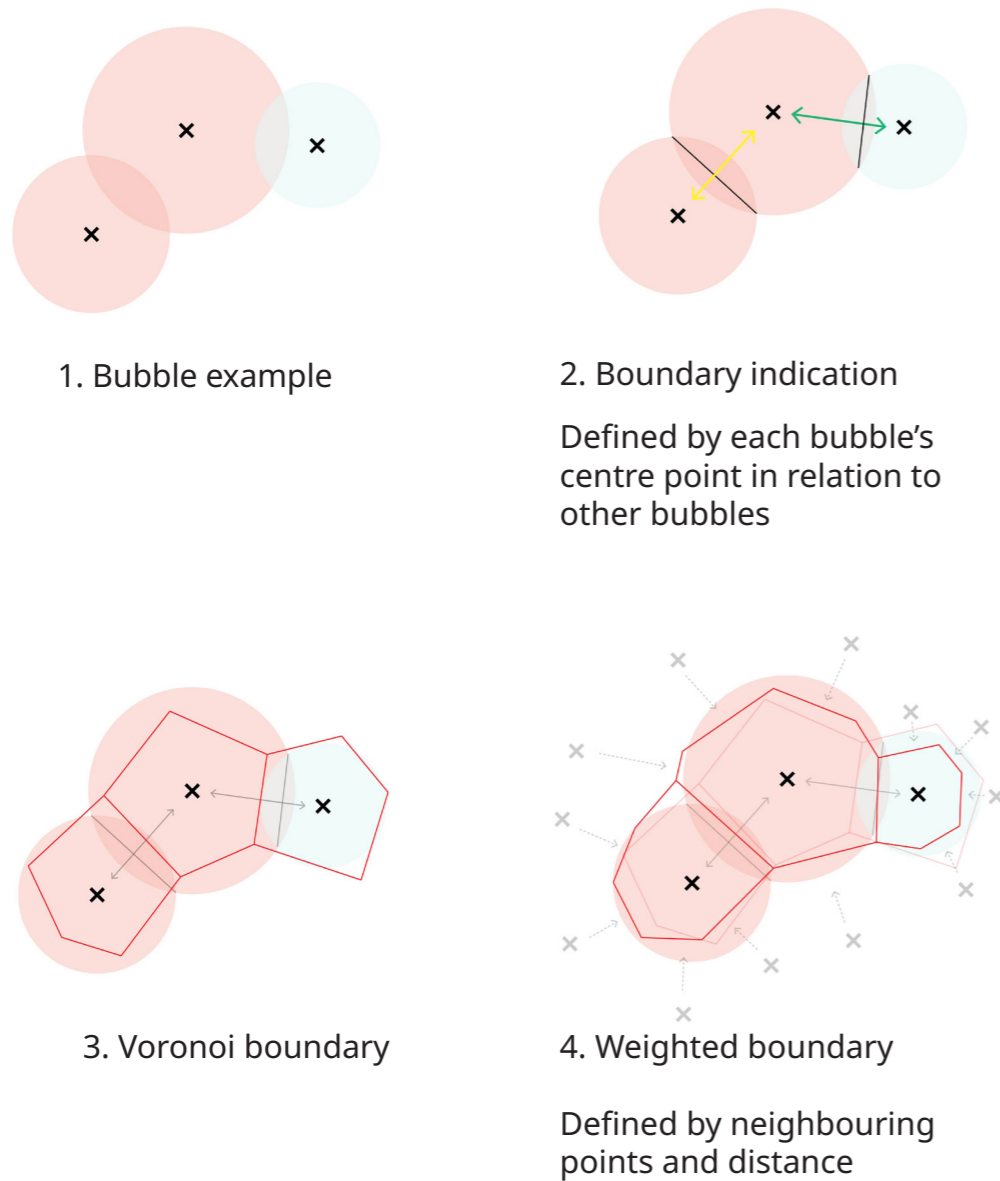
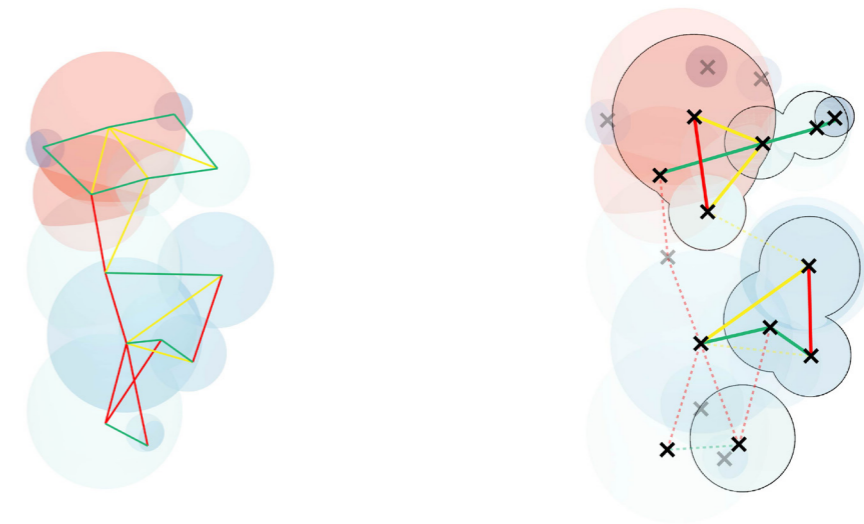

Fig 6.2.1: Voronoi analysis diagrams

## Voronoi application



Circulation

Zone centroid

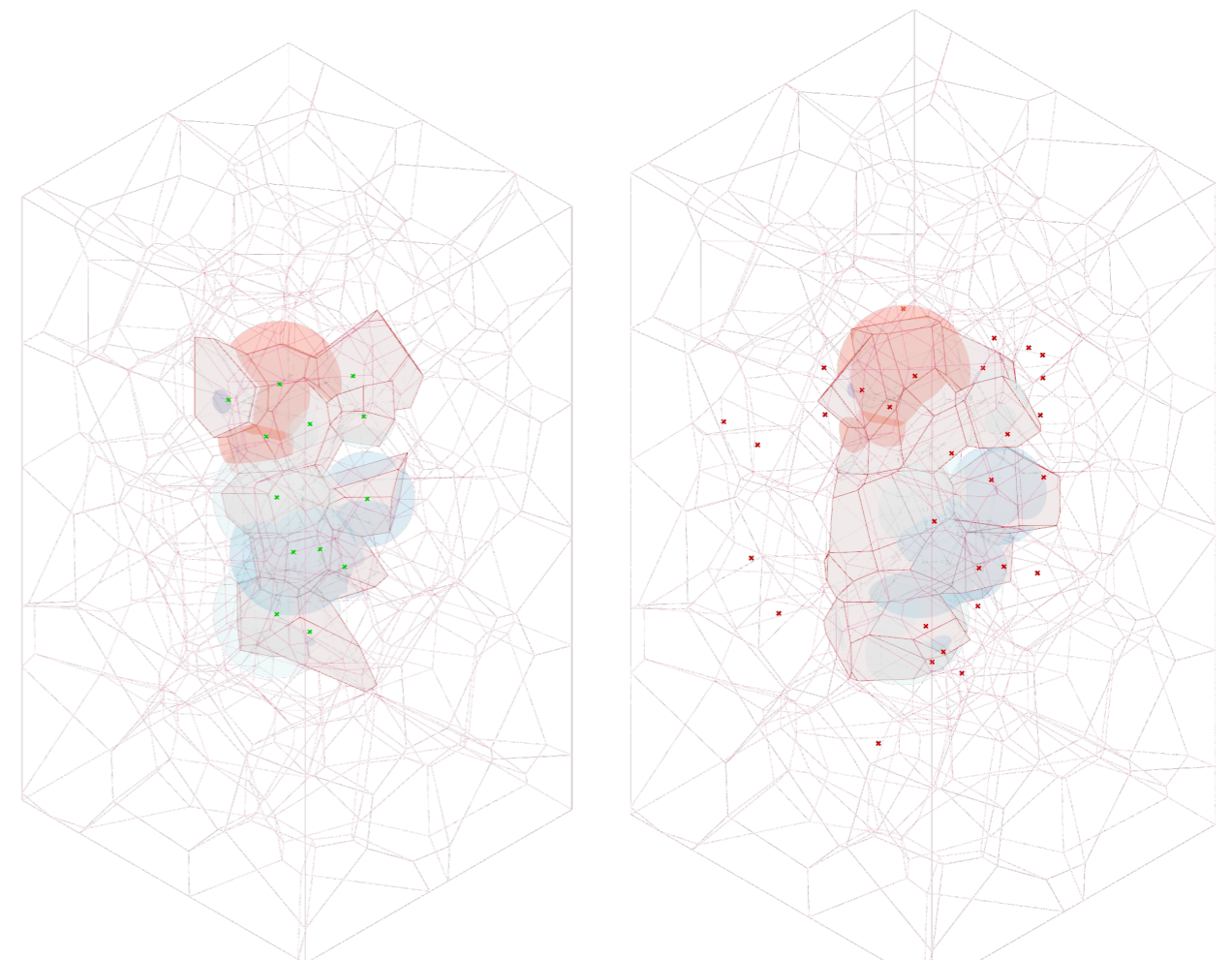

Voronoi boundary

Weighted boundary

Fig 6.2.2: Voronoi application

## Section (macro)

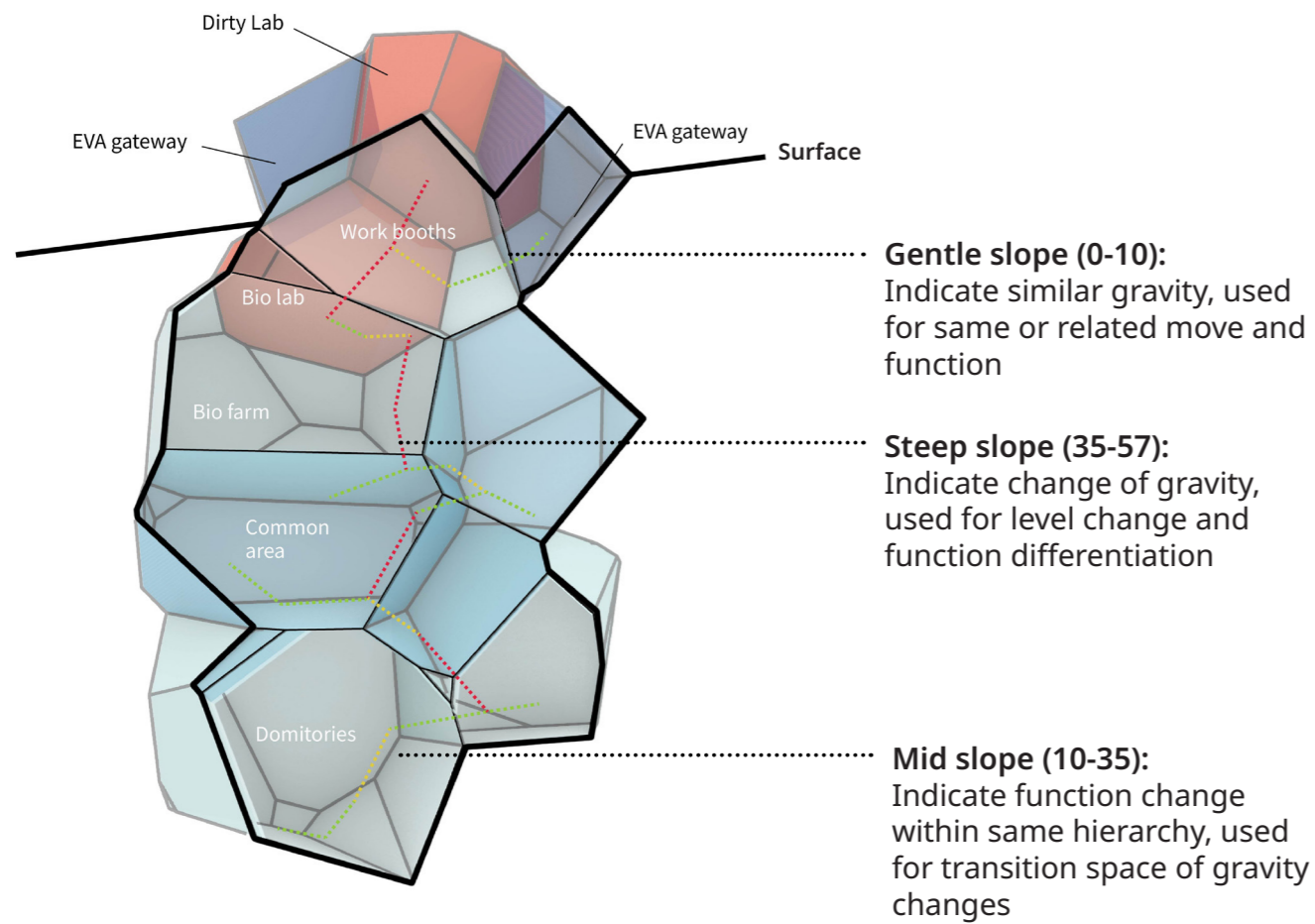
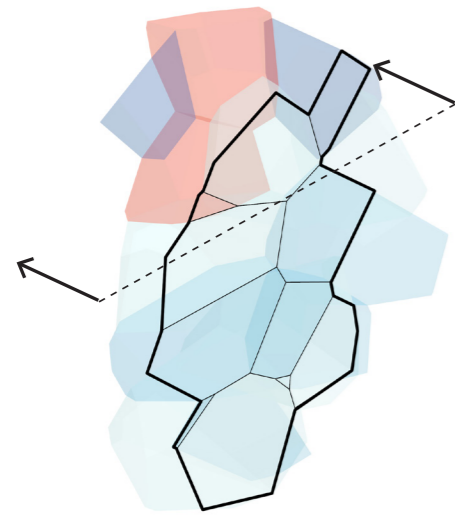
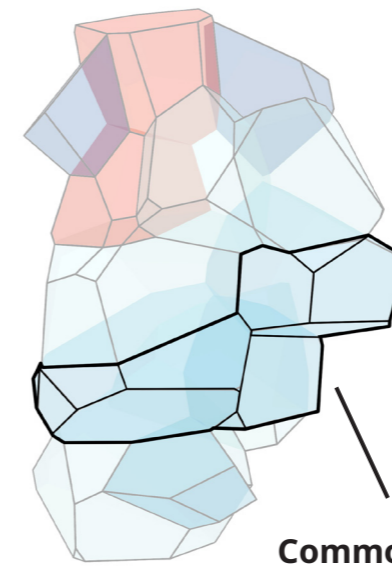

Fig 6.2.3: Voronoi macro section

## 6.3 Architectural exploration (meso)



As the main transition space between lunar time and internal time, common area connects Bio-farm, workstations and private space like dormitories.

Previously in the marco scale, each zone is defined by a dominate perception of gravity, distinguished by primitive diagram of slope gradient and relations.

In this sector, landing space is further explored as relationships between individual gravities inside one zone.

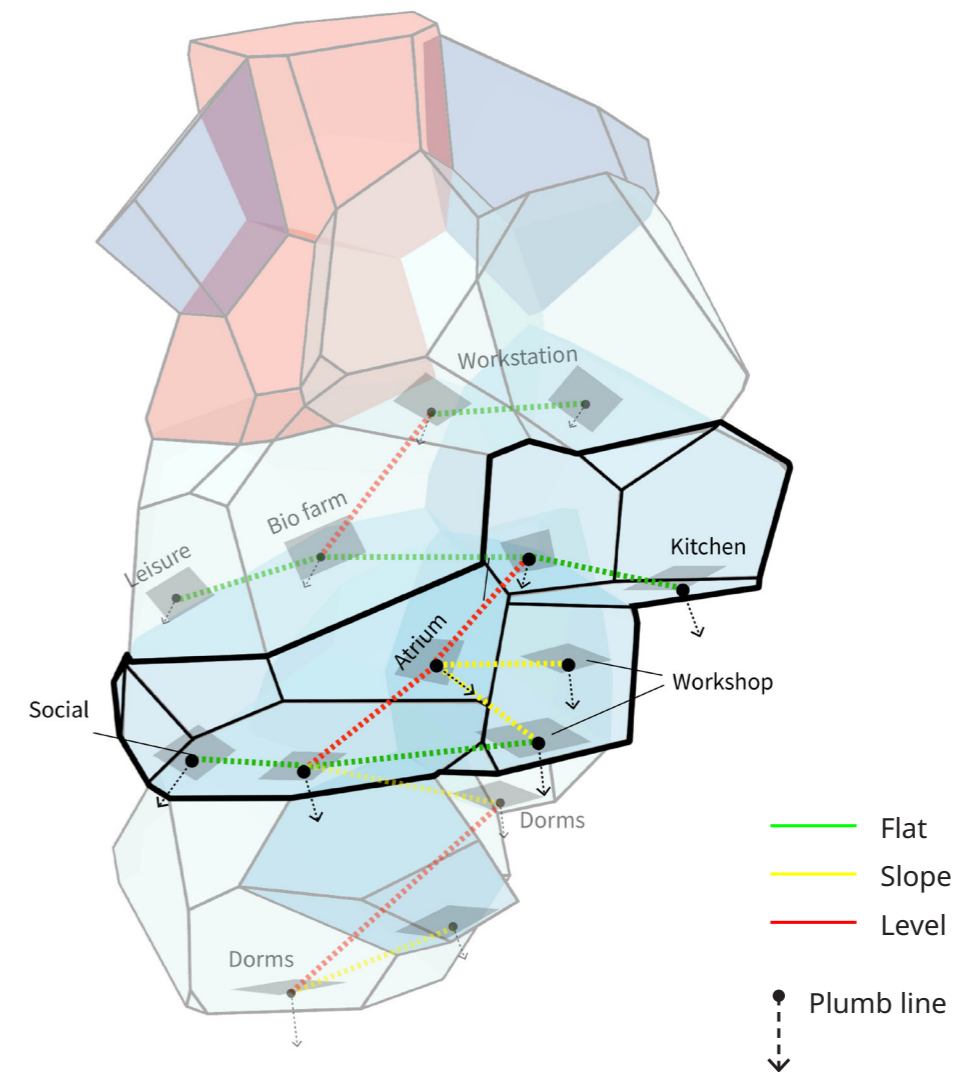

Fig 6.3.1: Common area circulation

## Inside Common area

Taking all related perception of gravity in to consideration, the common area can have external connections (bio farm, workstation, domitory) as well as internal relations. Different slopes also indicate relations, where a gradual slope offers transition and steep slope offer privacy.

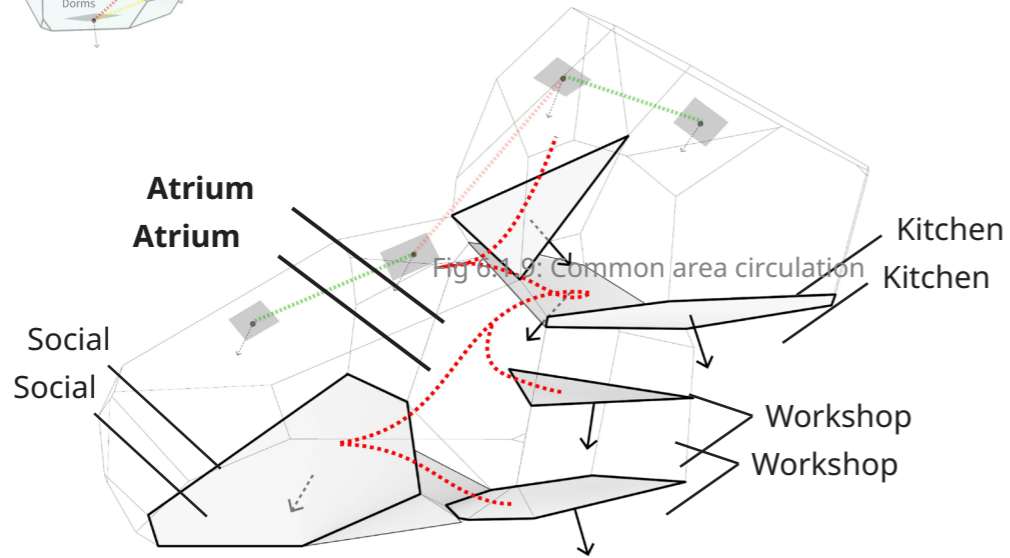
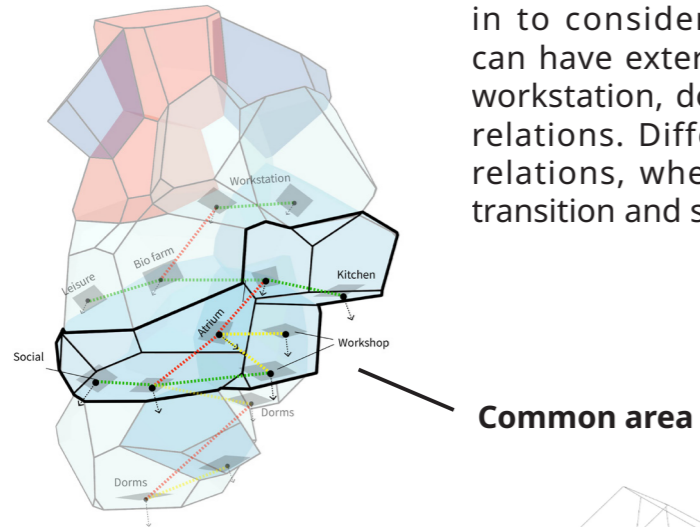

Fig 6.3.2: Landing surface

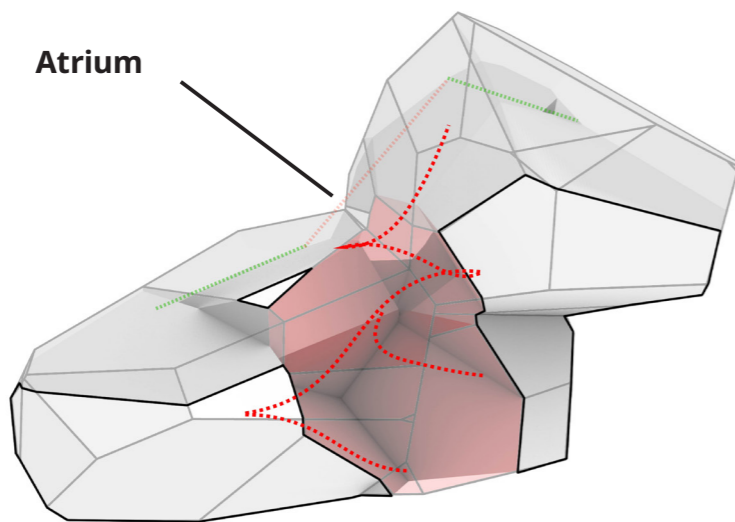

Fig 6.3.2: volume extraction

## Section - common area (meso)

While landing surfaces are not on the same level, sections are rotated to show better 3D quality

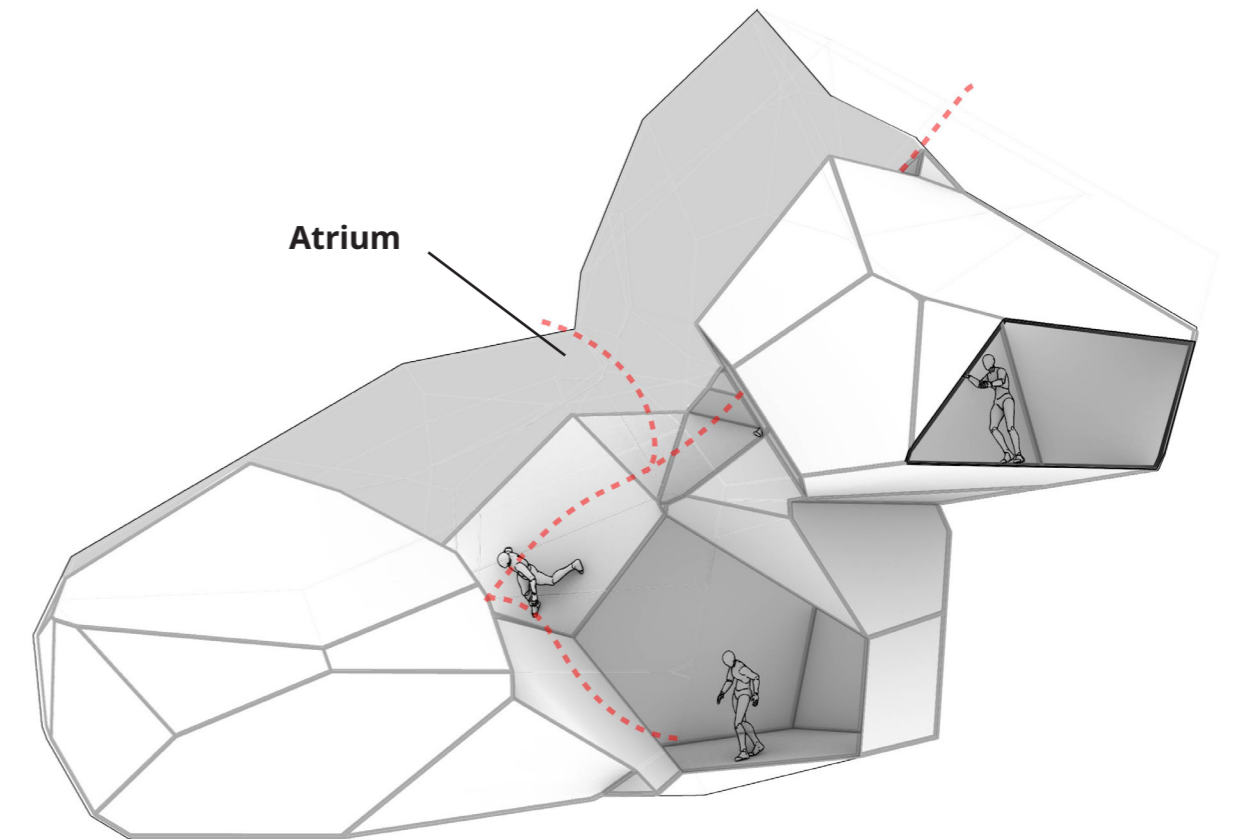
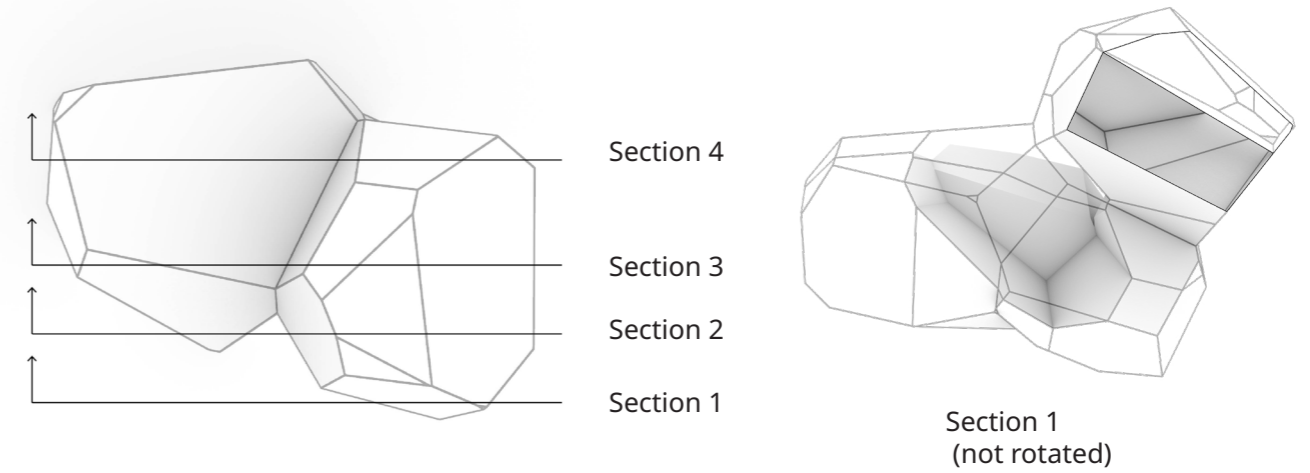

Fig 6.3.3: Section 1

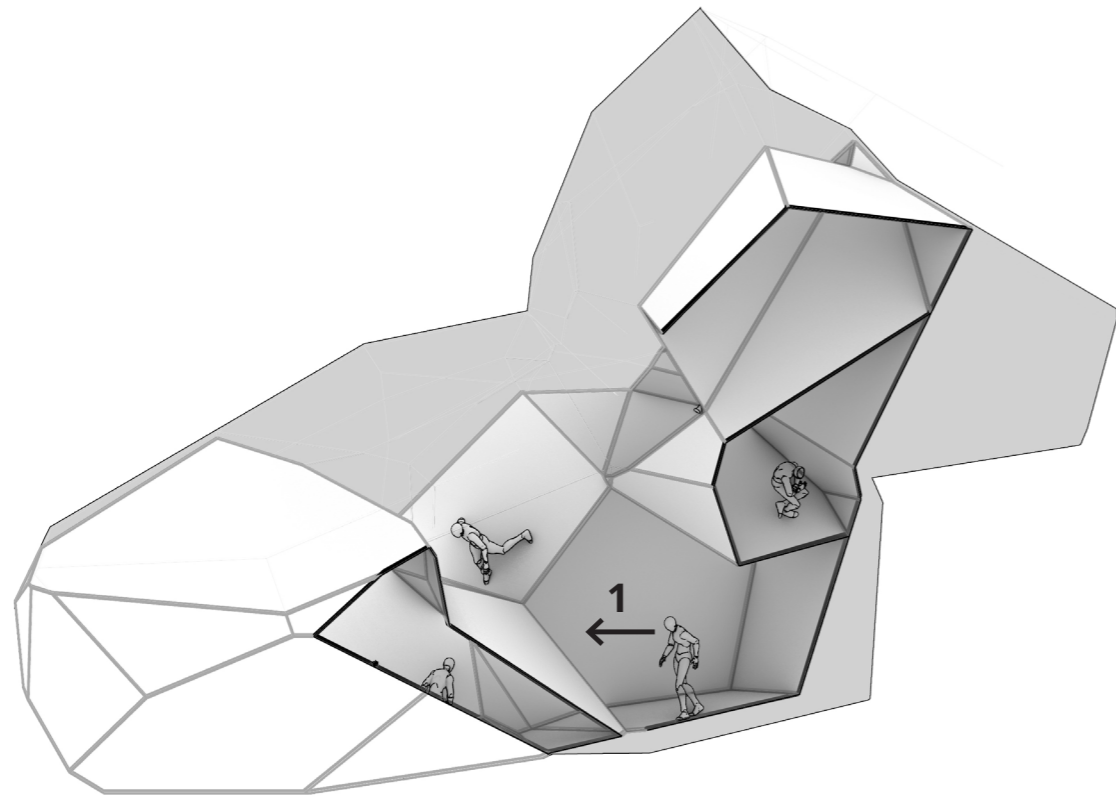

Fig 6.3.4: Section 2

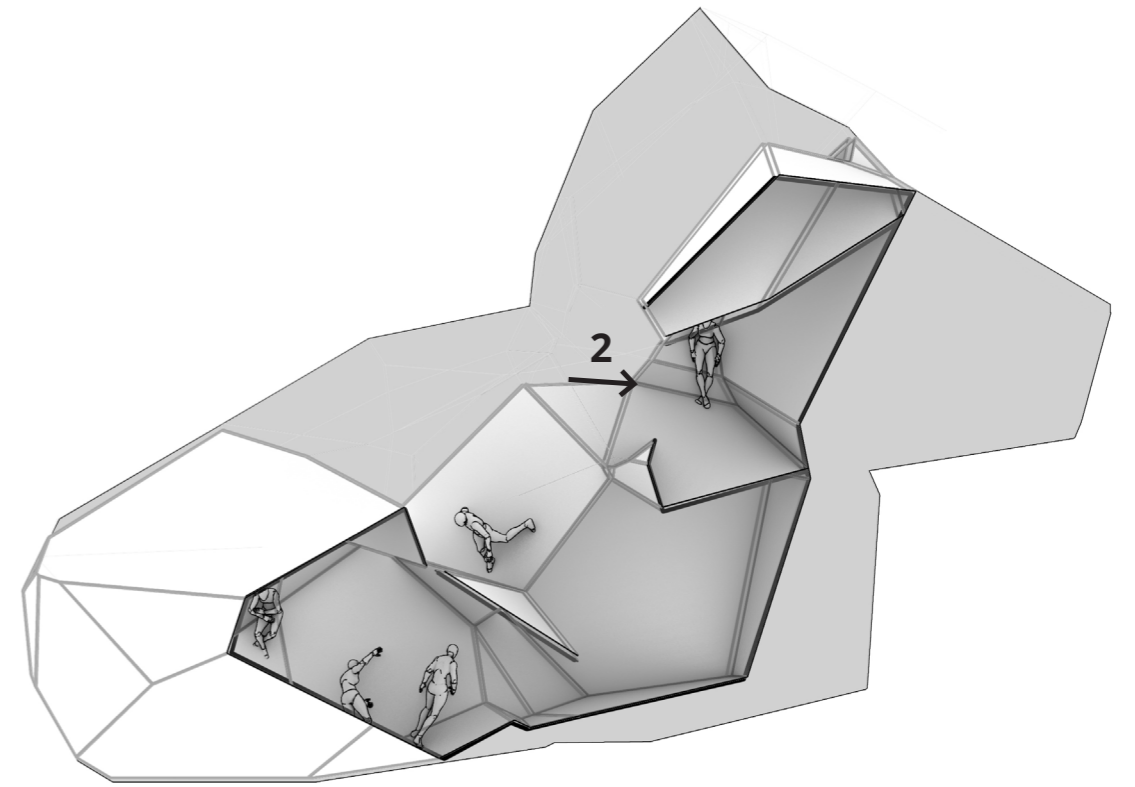

Fig 6.3.6: Section 3

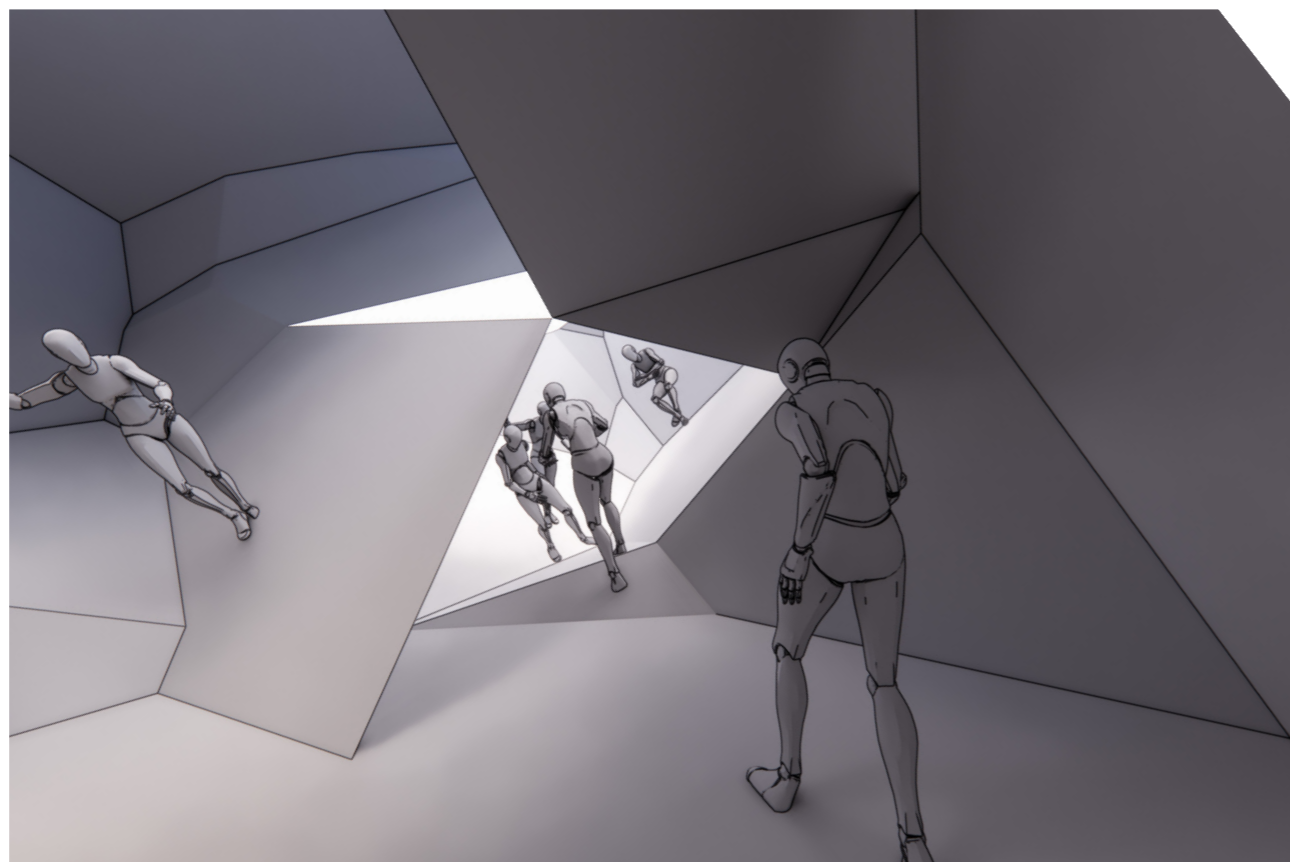

Fig 6.3.5: View 1: From workshop to common area

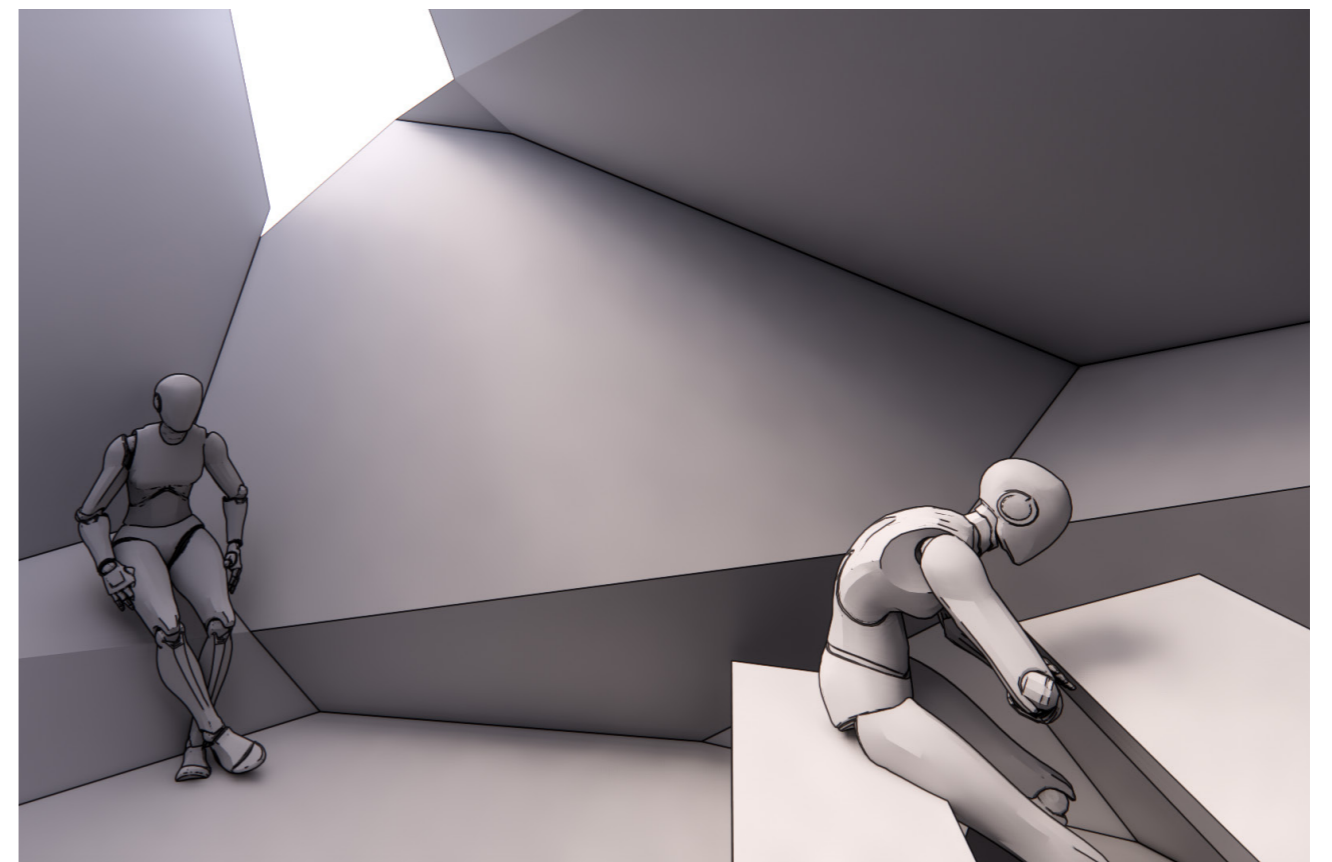

Fig 6.3.7: View 2: Inside private workshop

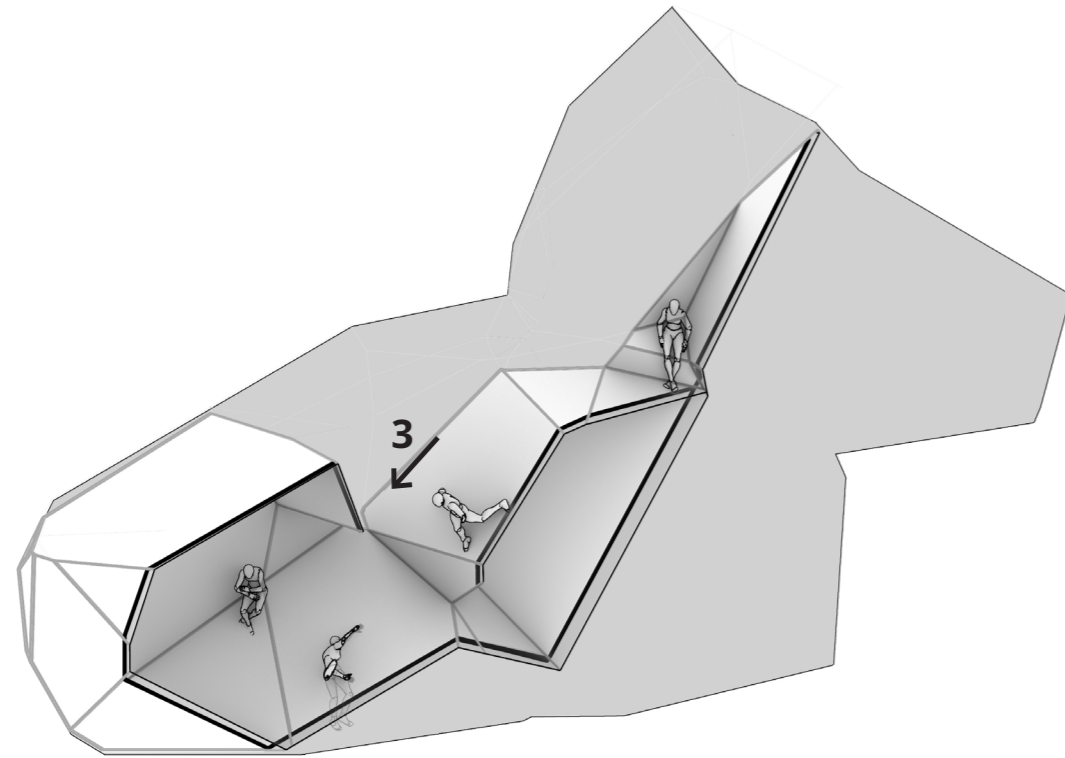

Fig 6.3.8: Section 4

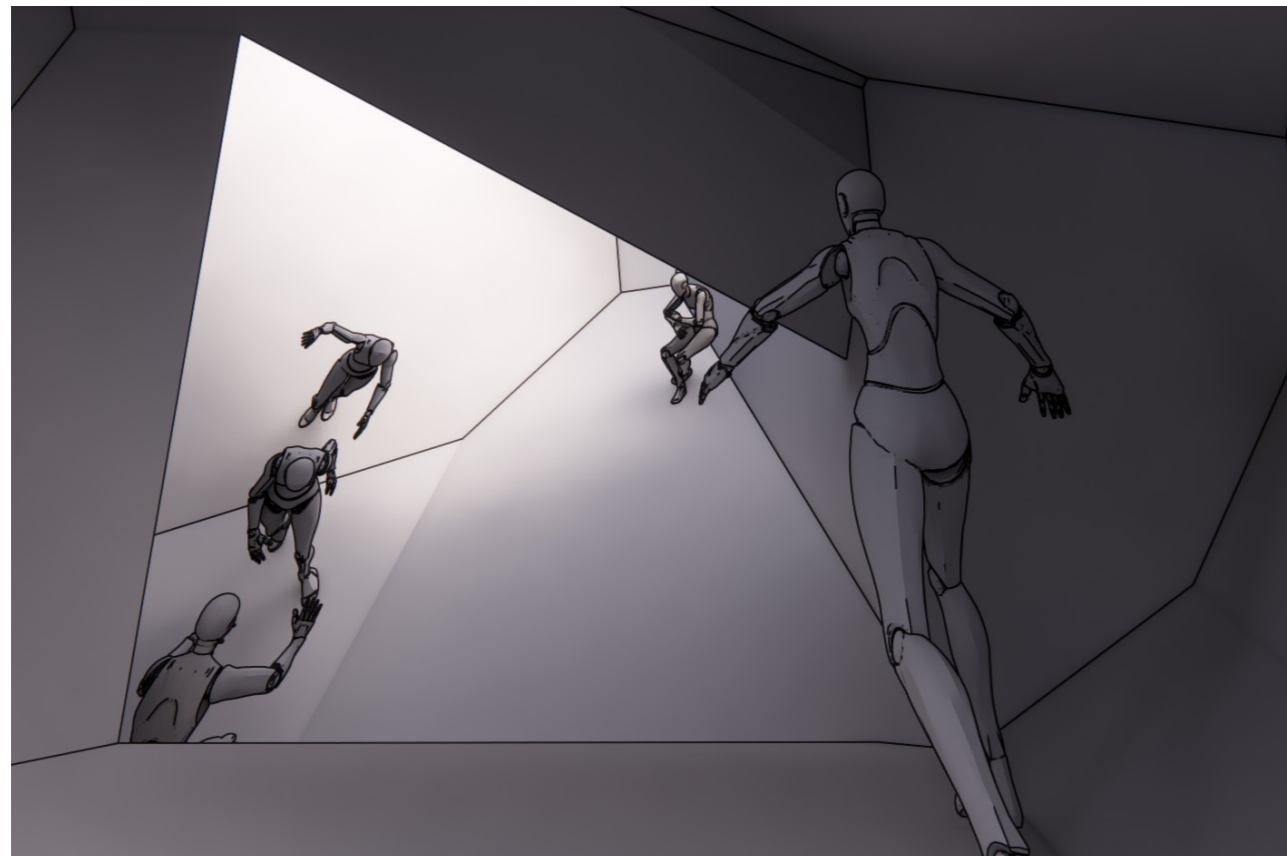

Fig 6.3.9: View 3: From ramp to common area

## Iso-surface transformation (meso)

Although Voronoi method can identify standing surface and volume, they are also faceted. In order to smooth the transition, Gyroid is applied to find the most fitted shape that follows habitants' cognition of gradual change

### Why Gyroid

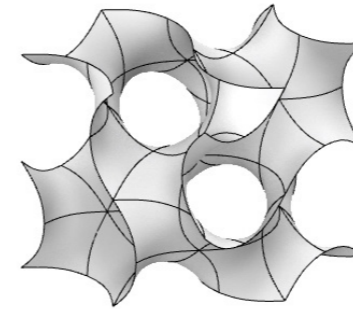

Fig 6.3.10: gyroid pattern

With only minimal surface considered, Gyroid will be used to connect visual anchors, without defining the concept of "floor" (result of gravity vertical) but complete relying on the gravity cues of entering other spaces.

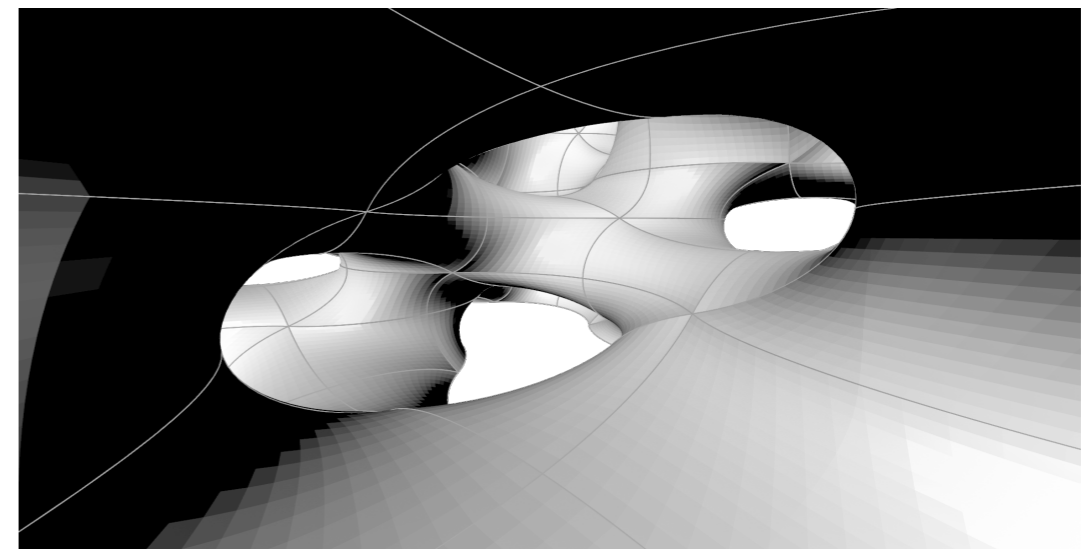
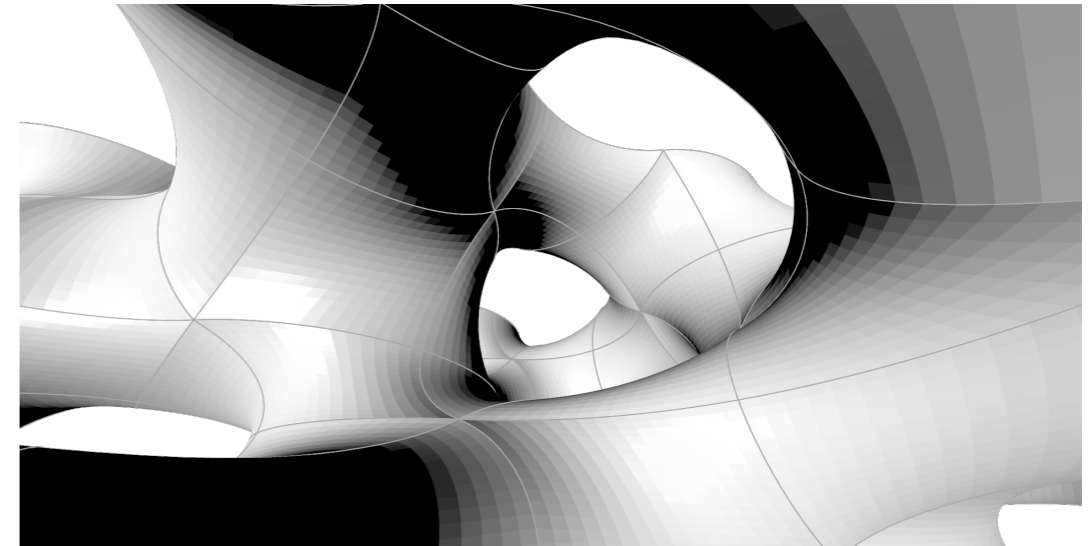
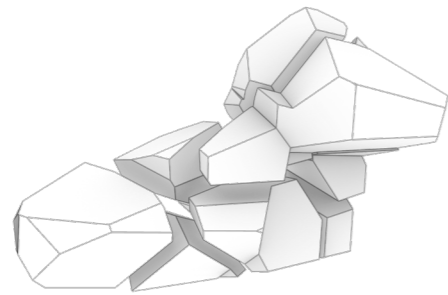

Fig 6.3.11&12: Gyroid spatial impression: connection (up) and room view (down)

## Iso-surface transformation (meso)

Take advantage of Voronoi approach, faces can be extracted and categorized to landing surface (force vector) and visual receiver (visual vector)



### 1. Define volume

Determine the bounding volume of every partition and room

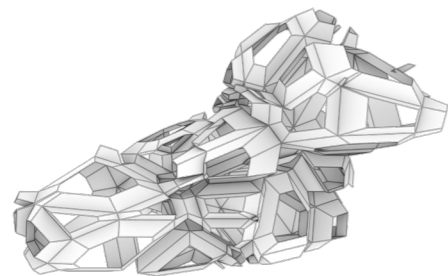

### 2. Extract landing and visual surfaces

Within the voronoi cell, there are landing surfaces and visual surfaces. In this step, they are set open from iso-surface calculation (no floor defined)

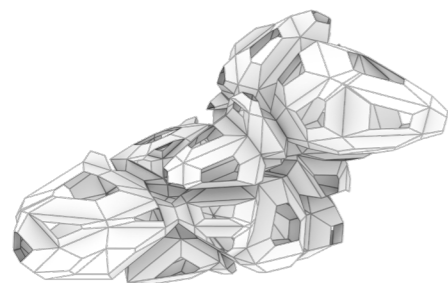

### 3. Select opening and closures

With open and closure analysis, these surfaces can serve as different purposes:

- Full close: landing surface
- Full open: inter-connection
- **Scaled open: visual vectors connect to visual perception: wall-mount devices, faux windows, lights**

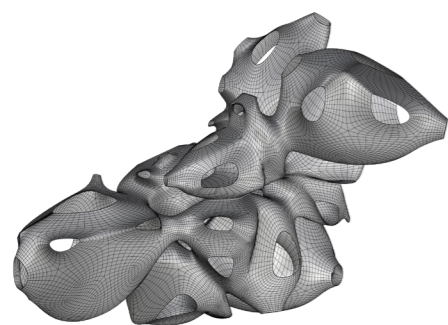

### 4. Iso-surface calculation

Method applied: Millipede & Weaverbird  
Compute & weld iso-surface meshes

Fig 6.3.13: Iso-surface transformation

## Revisit common area (meso)

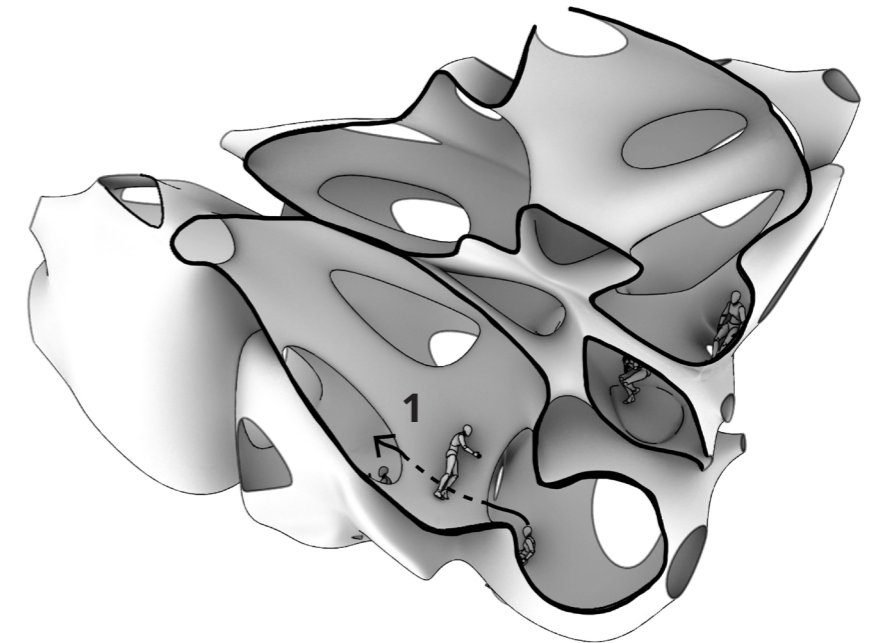
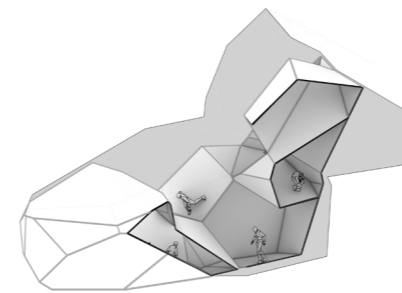

Fig 6.3.14: Section 2 (iso-surface)

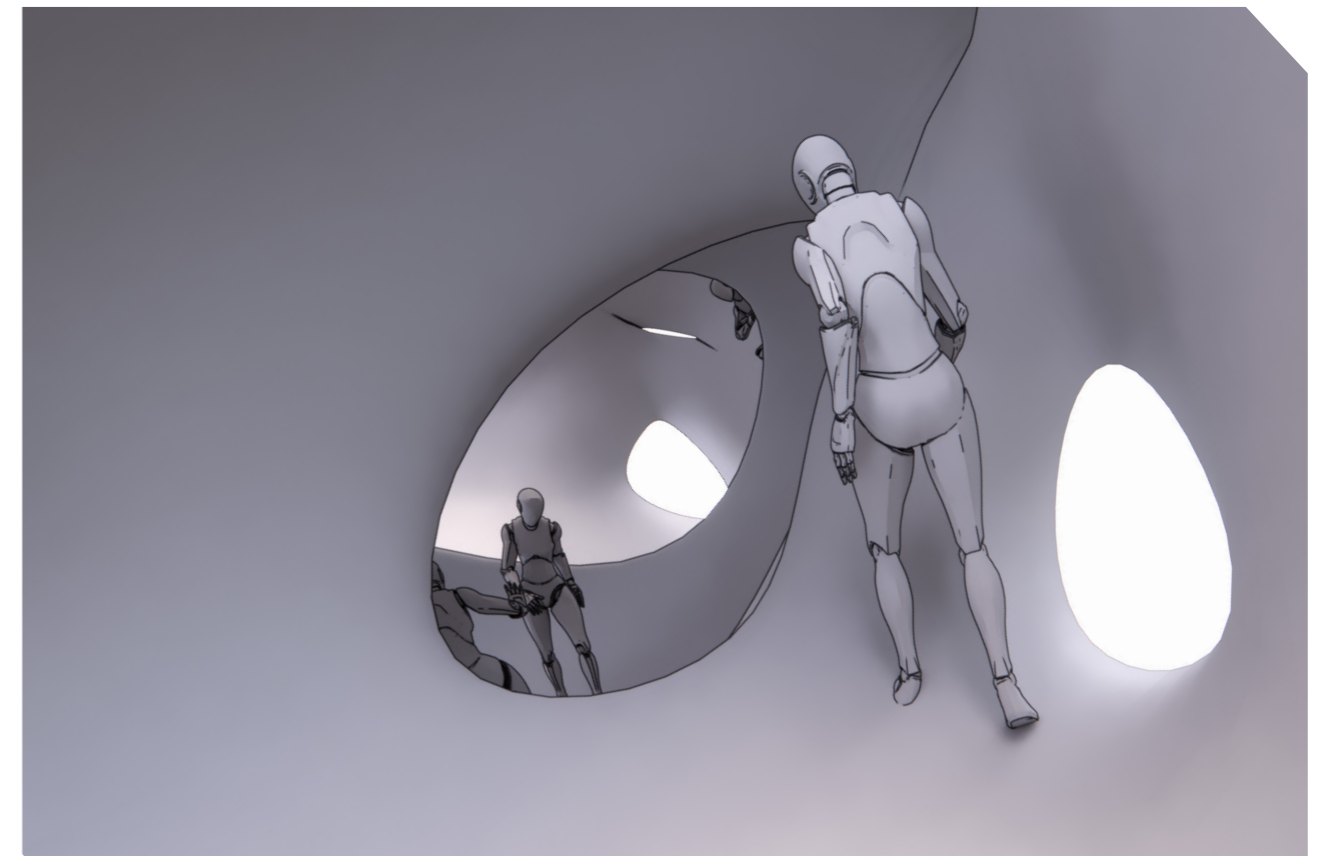

Fig 6.3.15: View 1: From workshop to common area

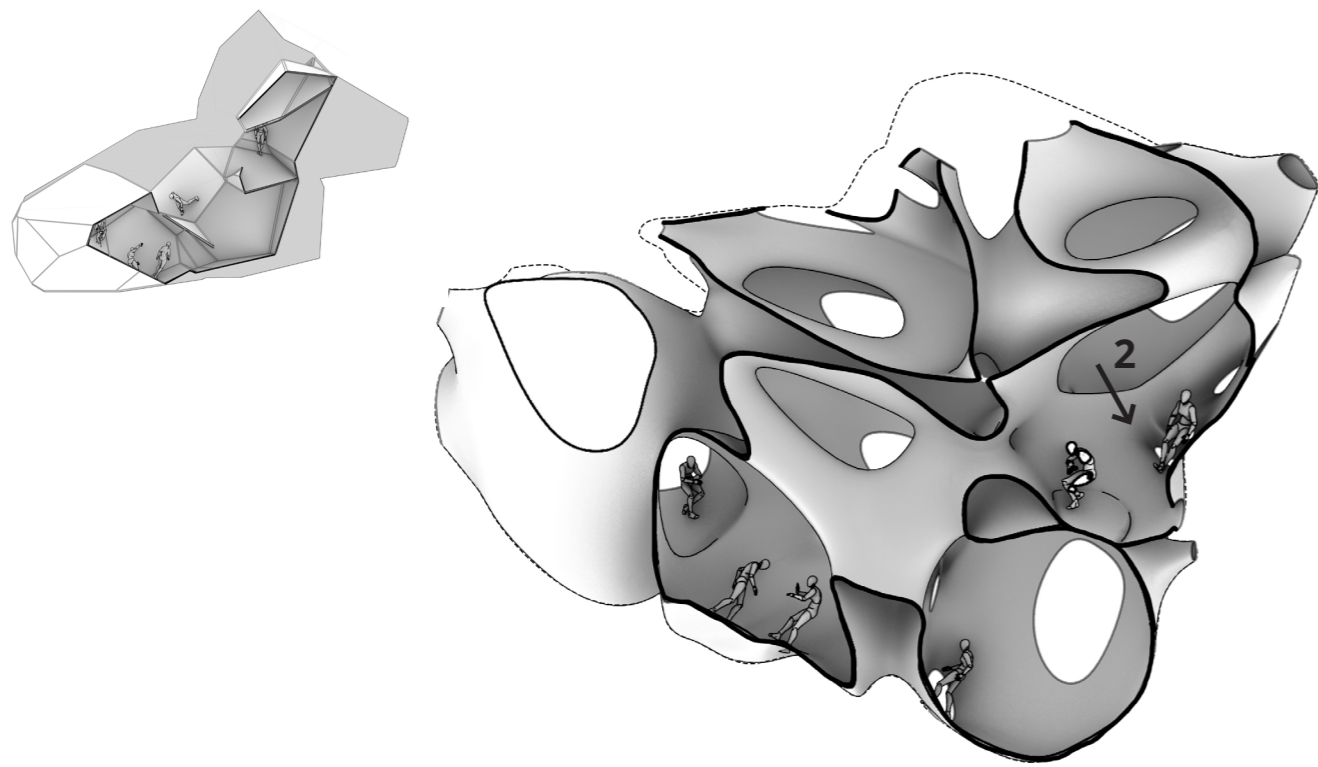

Fig 6.3.16: Section 3 (iso-surface)

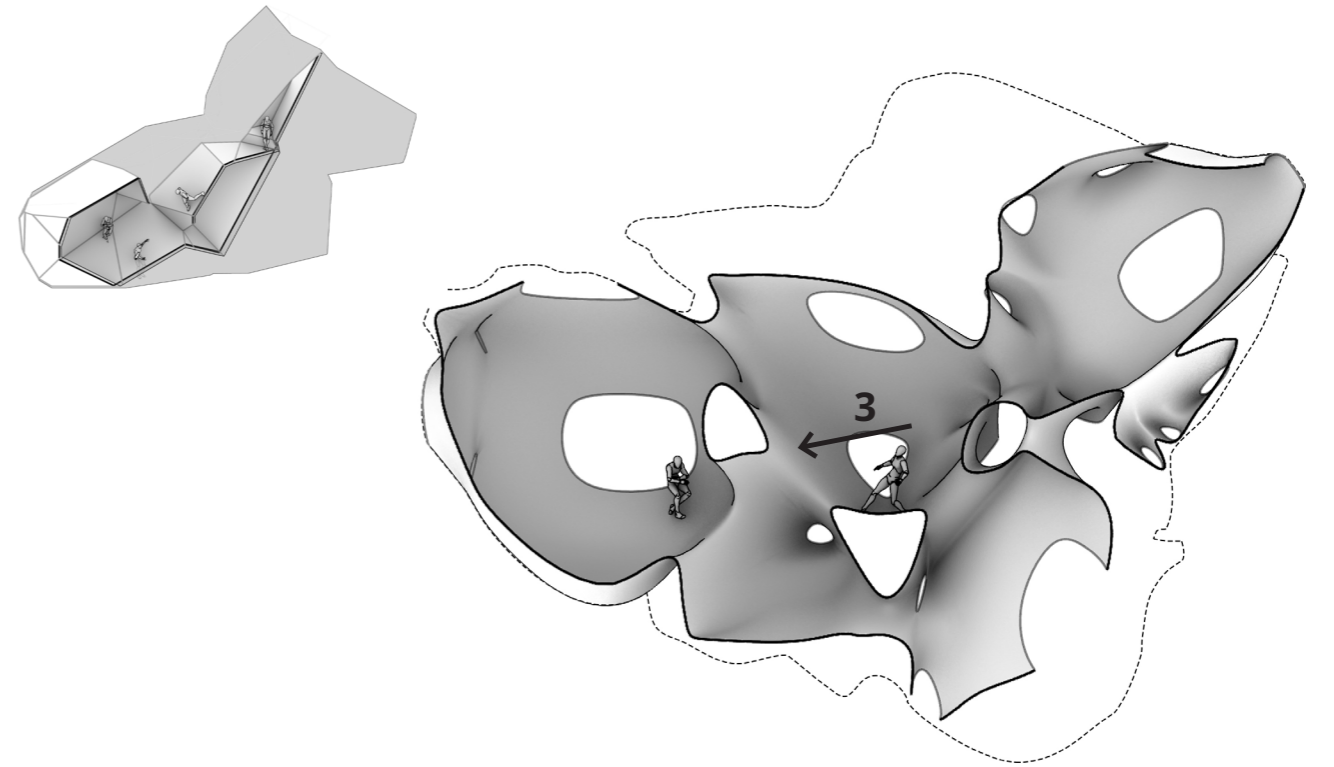

Fig 6.3.17: Section 4 (iso-surface)



Fig 6.3.17: View 2: Inside small workshop

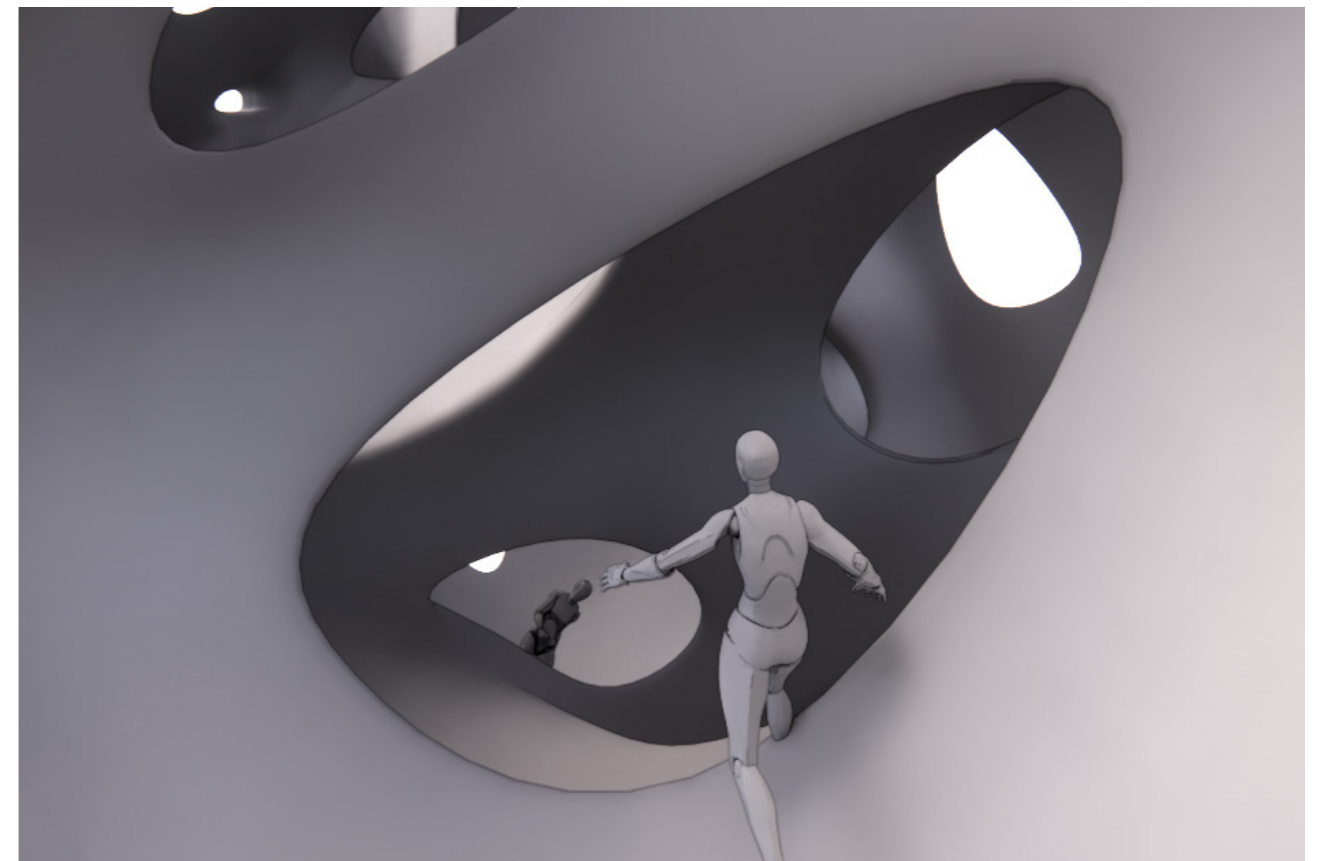

Fig 6.3.18: View 3: From ramp to common area

# Revisit common area (meso)

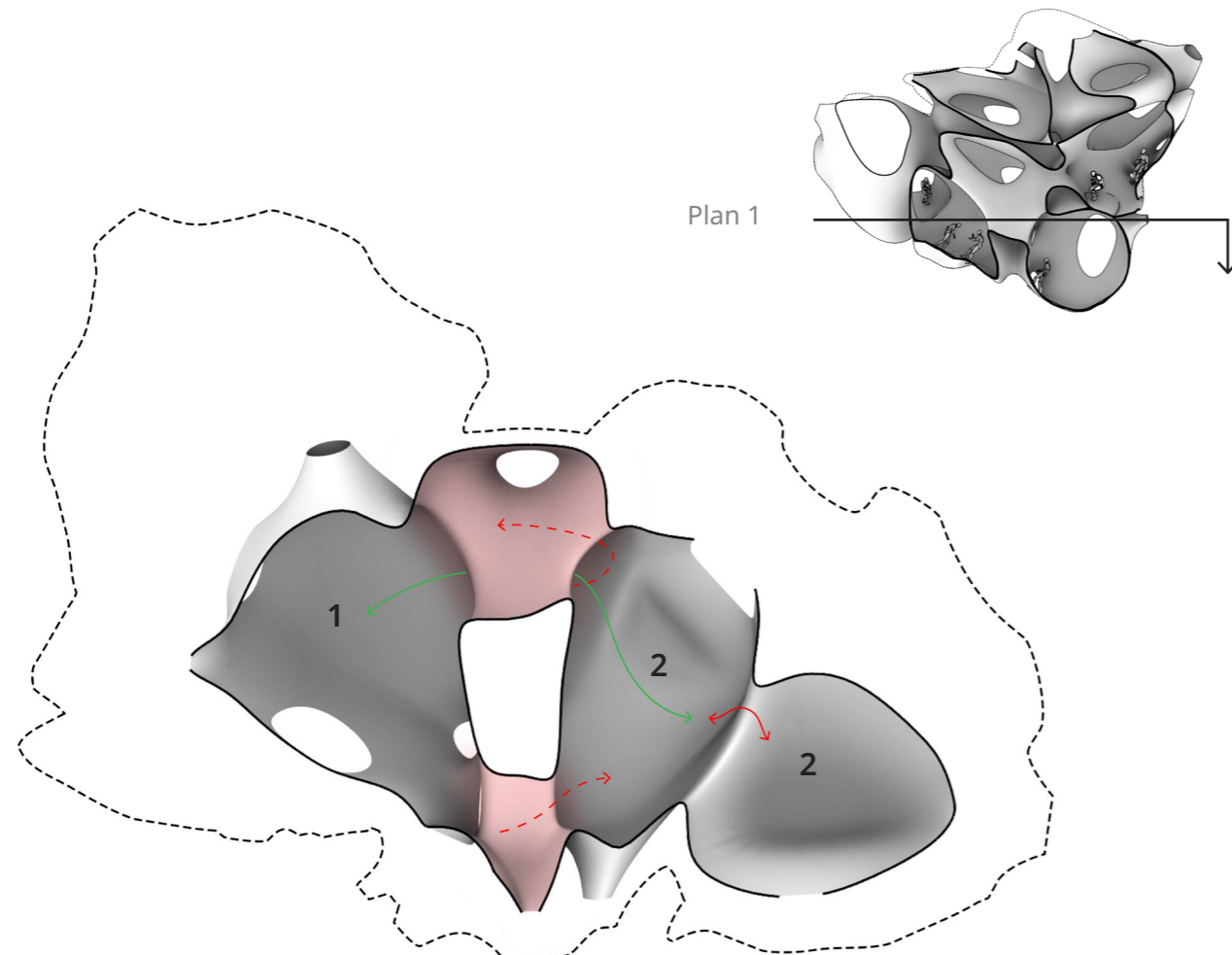

Fig 6.3.19: Plan 1 (iso-surface)

- Flat
- Slope
- Level
- Circulation

- 1. Workshop (large)
- 2. Common social area

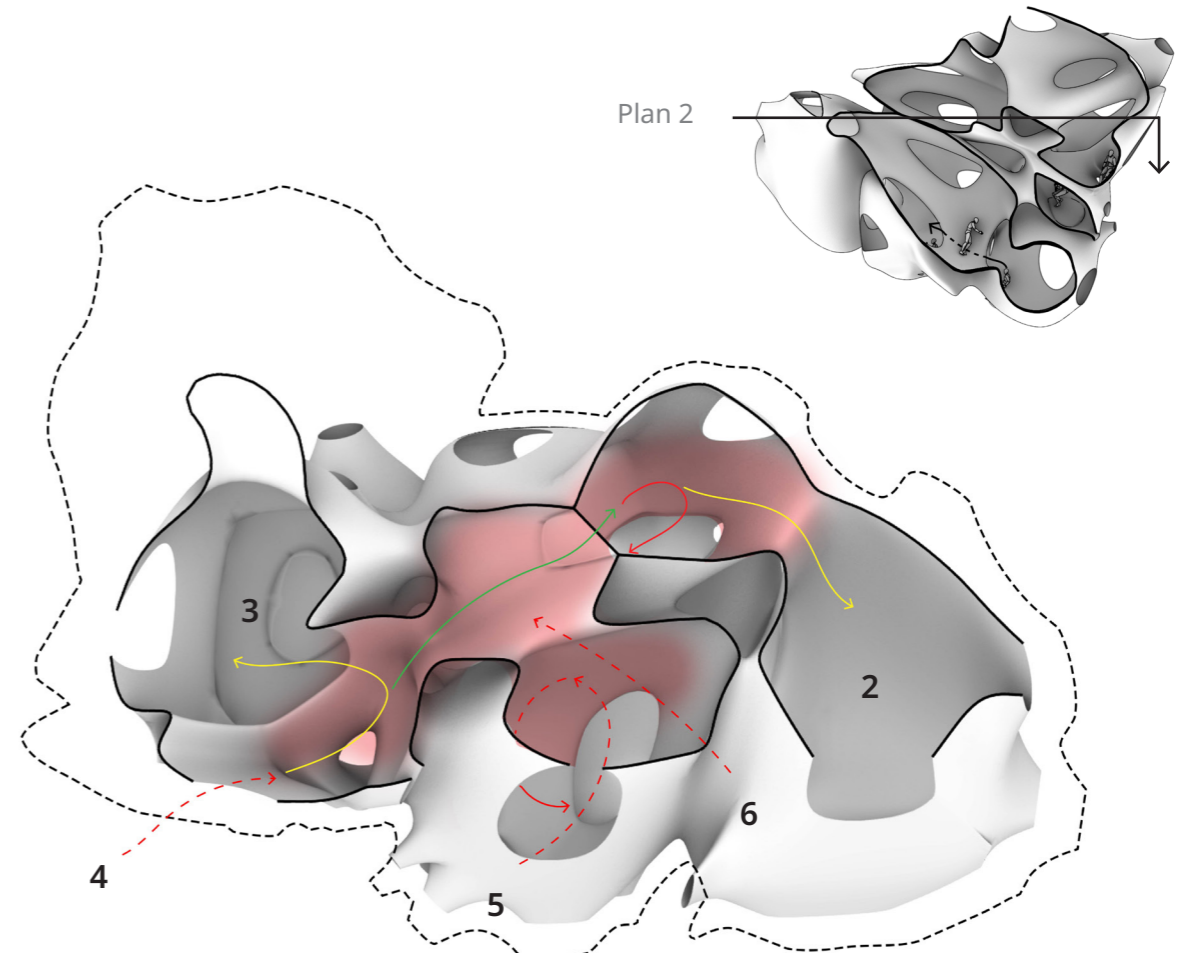

Fig 6.3.20: Plan 2 (iso-surface)

- Flat
- Slope
- Level
- Circulation

- 1. Workshop (large)
- 2. Common social area
- 3. Workshop (small)
- 4. Connection to workstation
- 5. Connection to Bio farm
- 6. Connection to leisure garden

## 6.4 Proof of concept (micro)

In order to test whether certain IsoValue would house sufficient volume and address user's reclaiming of the individual 'plumb line', the original visual and force anchors are implemented in a segment.

### Micro space: private workshop

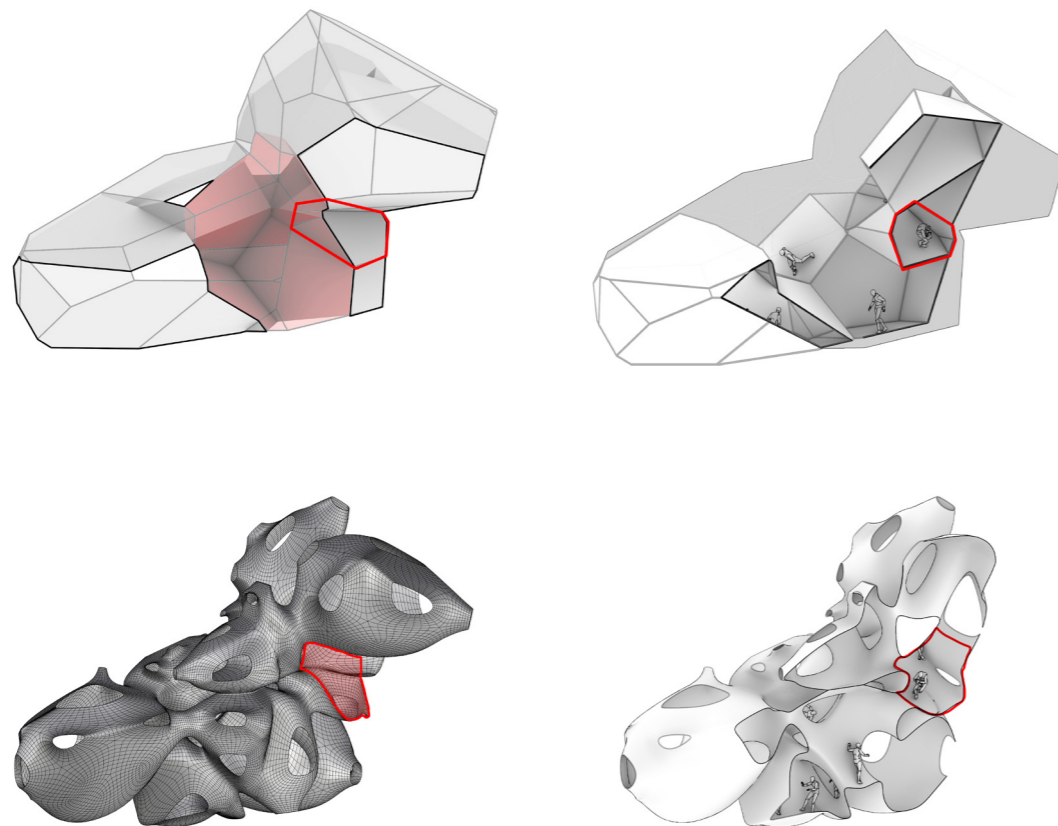

Fig 6.4.1: Micro (voronoi) up; (isosurface) down

### Micro space: workshop table environment



Fig 6.4.2: Force & visual vectors

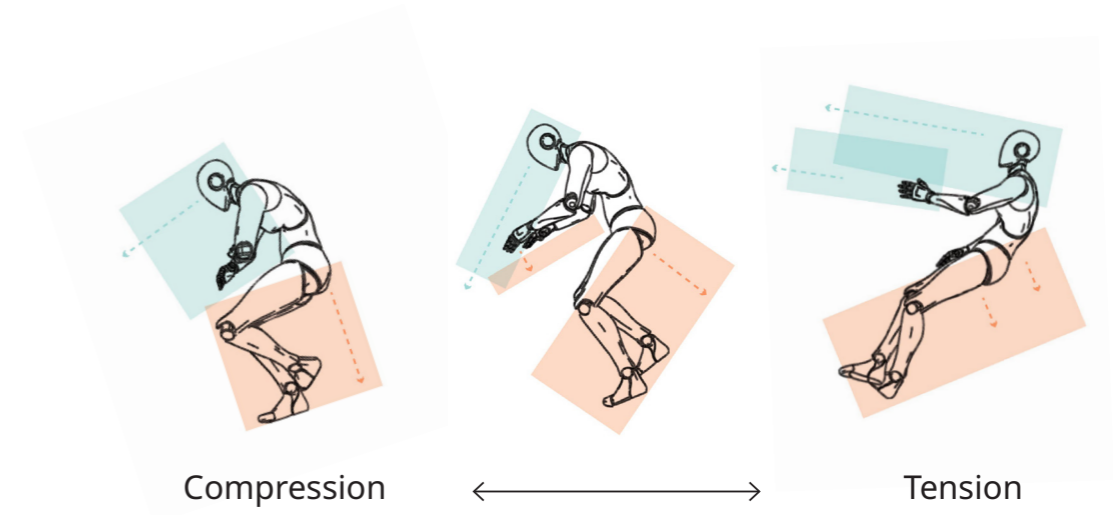

Fig 6.4.3: Body movement sequence

In the case of small workshop, habitant's perception of gravity can be object vertical: the chair, the working surface, lights... Again, we feel gravity from ambient environment rather than the weak 1/6G moon gravity.

# Object gravity

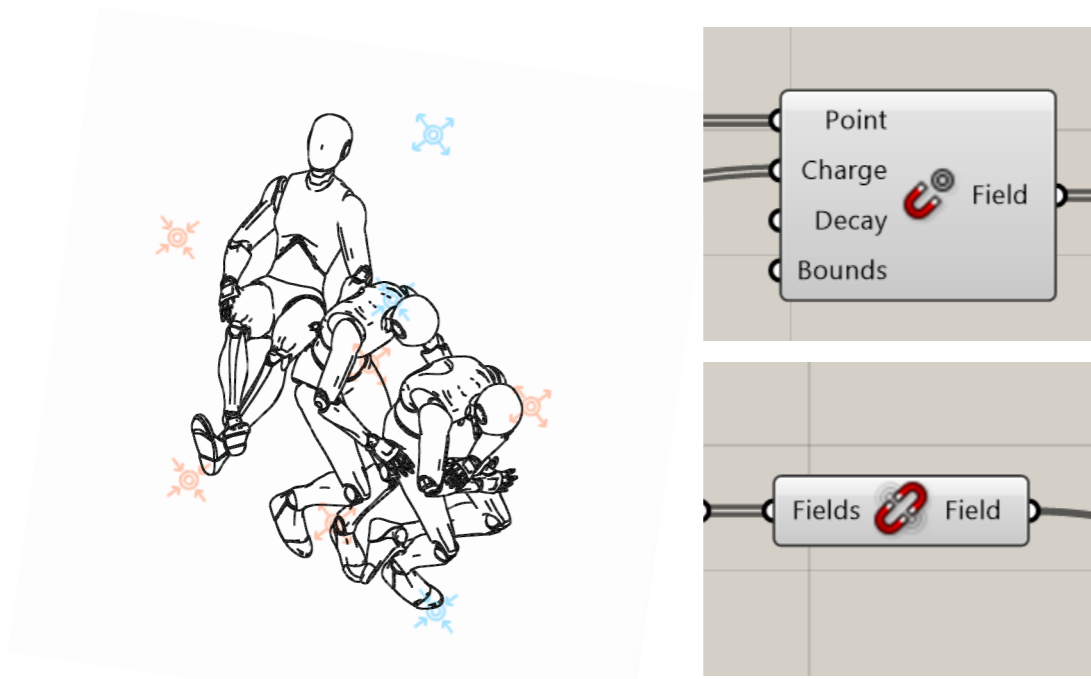

Fig 6.4.4: Charge points

Anchors either charges as compression or tension, trigger interior surfaces catering to habitant's perception of gravity.

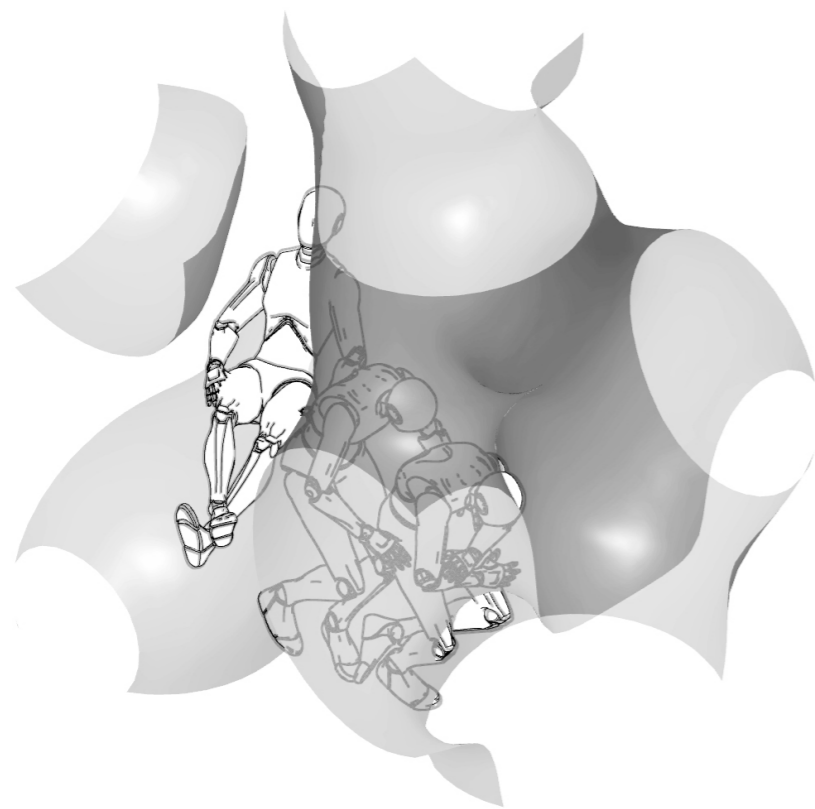
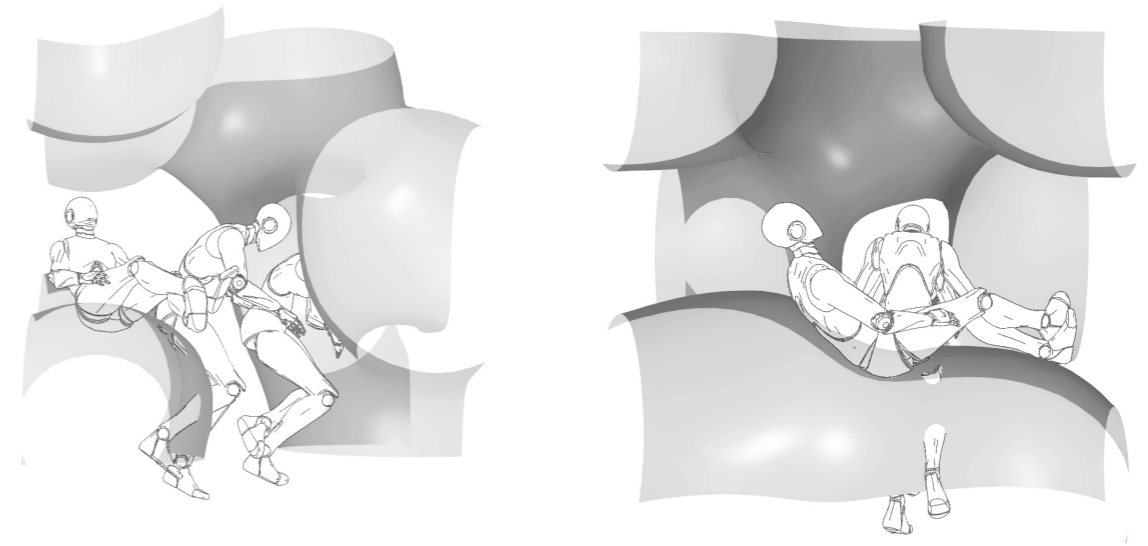

Fig 6.4.5: interior gravity cues setup

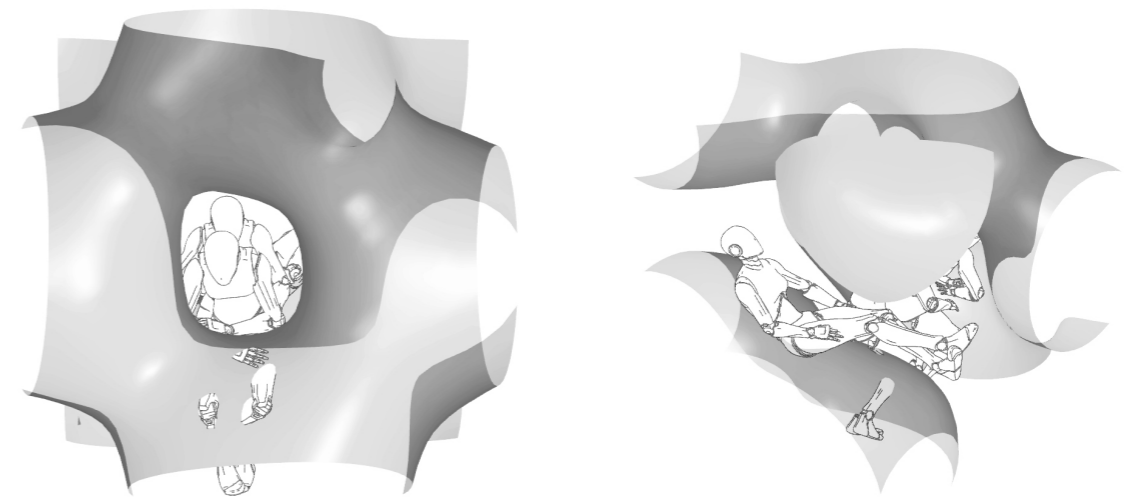

Fig 6.4.6: Evaluate output

## Positive & Negative space

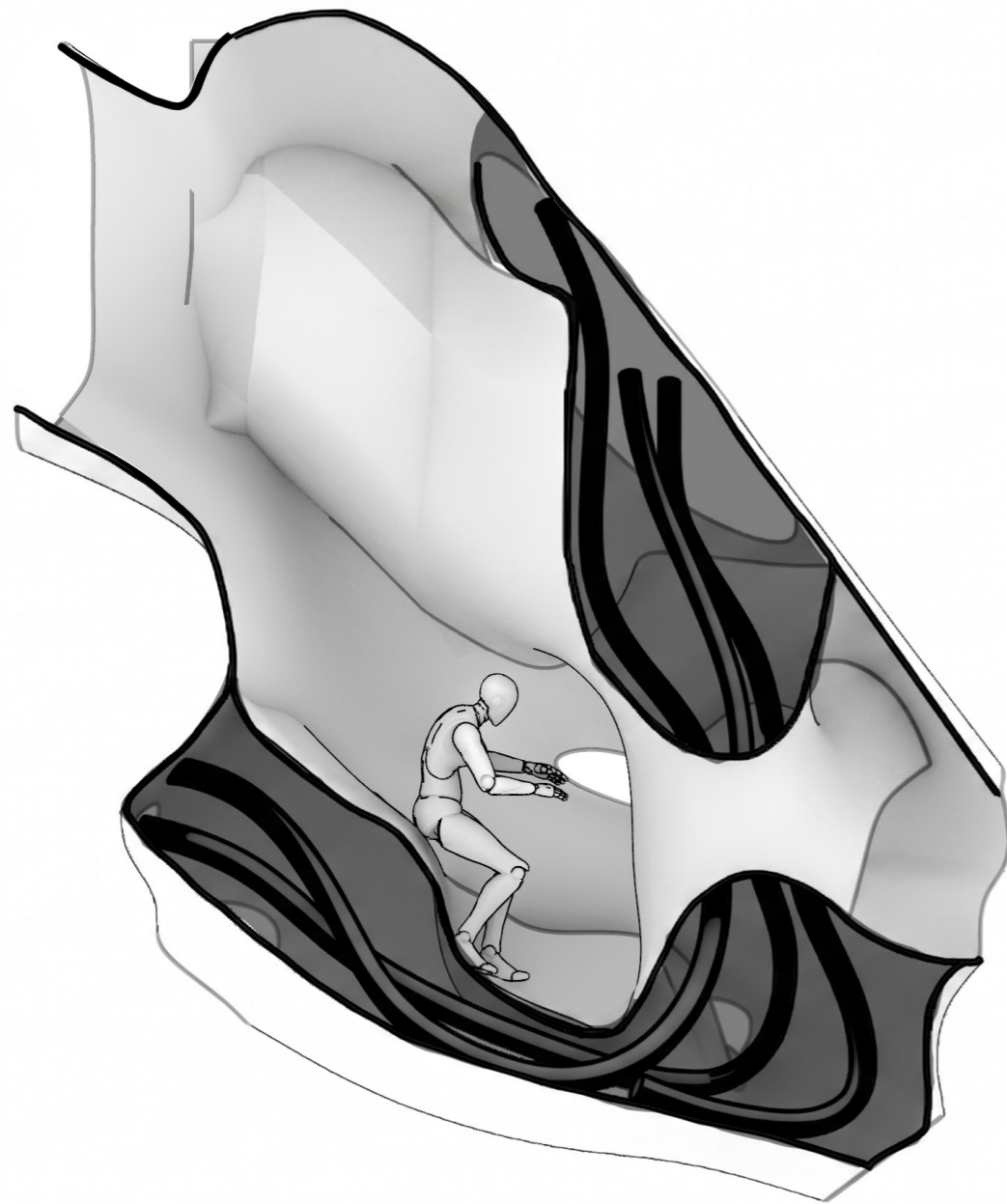

Fig 6.4.7: Workshop section (schematic)

Thanks to the computation of Gyroid, a series of negative space is automatically generated when forming working planes. This space can be used for service channels without interrupting the continuity of finishing surface.

## Material and construction



Fig 6.4.8: 3D printing lunar regolith, NASA, 2019

According to NASA (2015), Lunar regolith, together with binders, can be used as construction filaments for lunar habitats. Although there are debates about the type of binder should be used on the moon, the direction of FDM printing is an understood rule.

As the habitat is mostly built underneath the surface, the construction process will include excavation, set up foundation and support, and printing with robot arm from upside down.

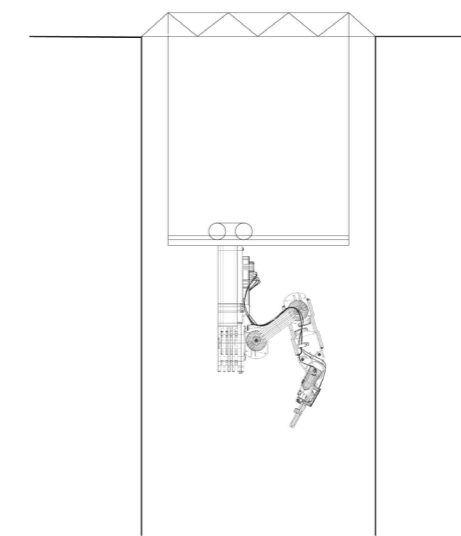

Fig 6.4.9: 3D printing from underground

Printing patterns

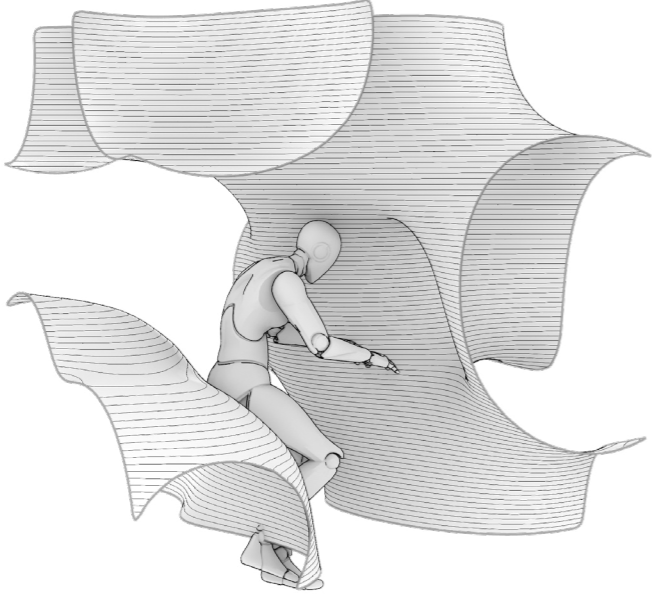

Fig 6.4.10: Normal level pattern

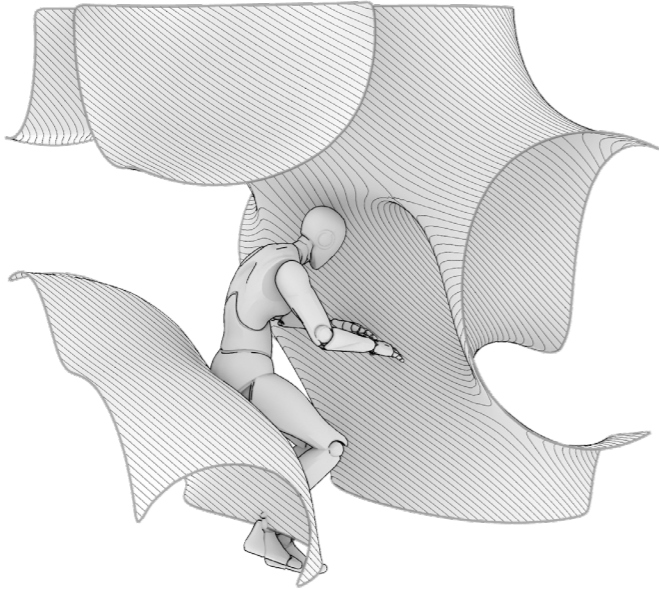

Fig 6.4.11: Pattern guides to corresponding gravity

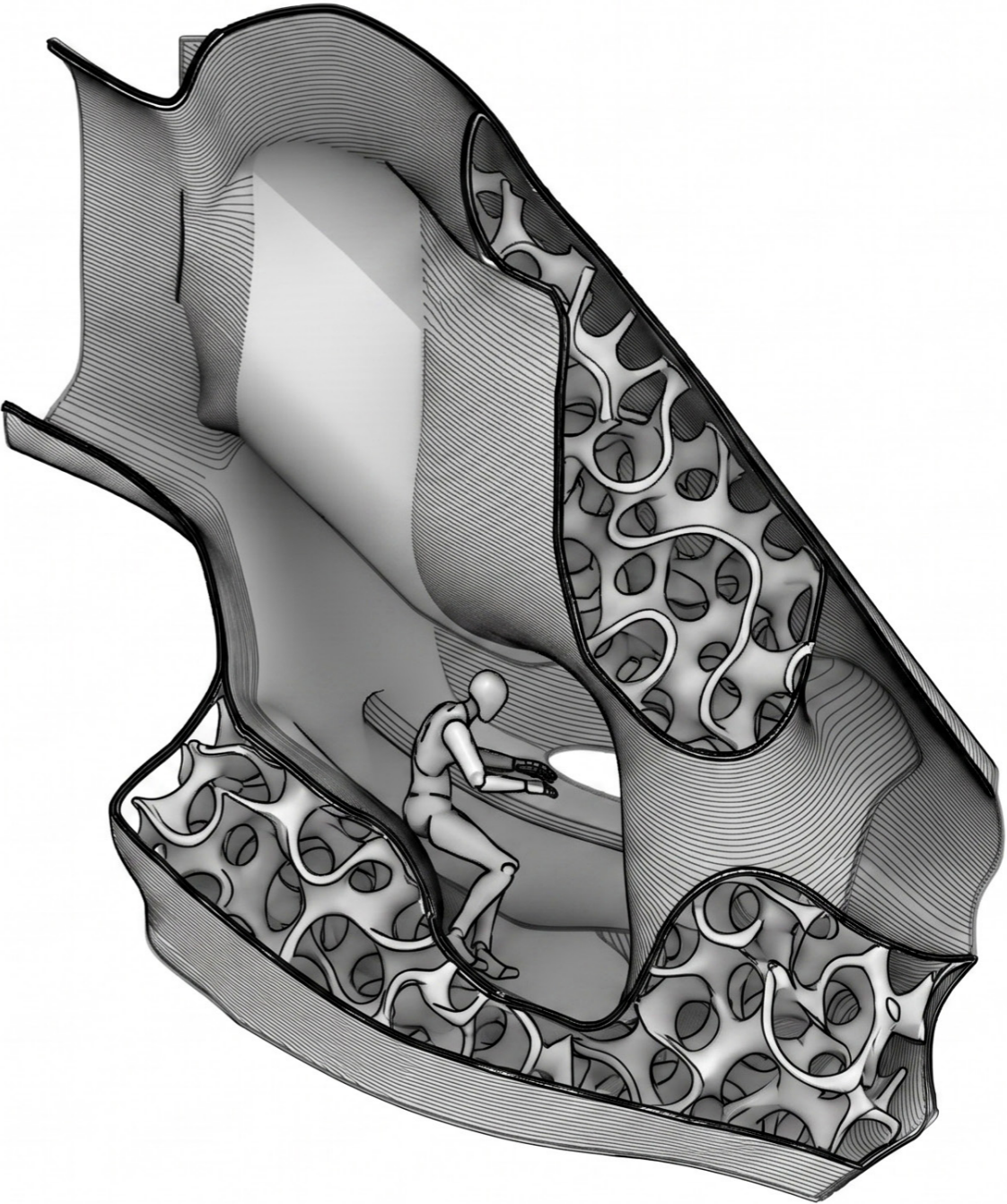

Fig 6.4.12: Section with infill structural pattern and outer finishing pattern

# 7.0 RELEVANCE

## 7.1 Off-earth Relevance

### Prevent illusion and maintain well-being for Lunar inhabitants

In Gibson's (2014) "The Ecological Approach to Visual Perception", he argued that poor spatial perception design can lead to severe cognitive load, or even illusion. While on earth, the effect of seasickness may provide a better description for this illusion. Seasickness occurs when the brain's "plumb line" and its "visual vertical" stop agreeing with each other. By aiming very far away, people regain visual anchor and thus the dizziness stopped.

While in moon EVA missions, low gravity worsen the situation of "plumb line", while the monotony environment provide few visual vertical, astronaut's motion may cause sickness, as stated in the report of Apollo 14 (NASA, 1971). The picture also shows the perception on the moon is less clear whether there's a hill or a pit in the distance.

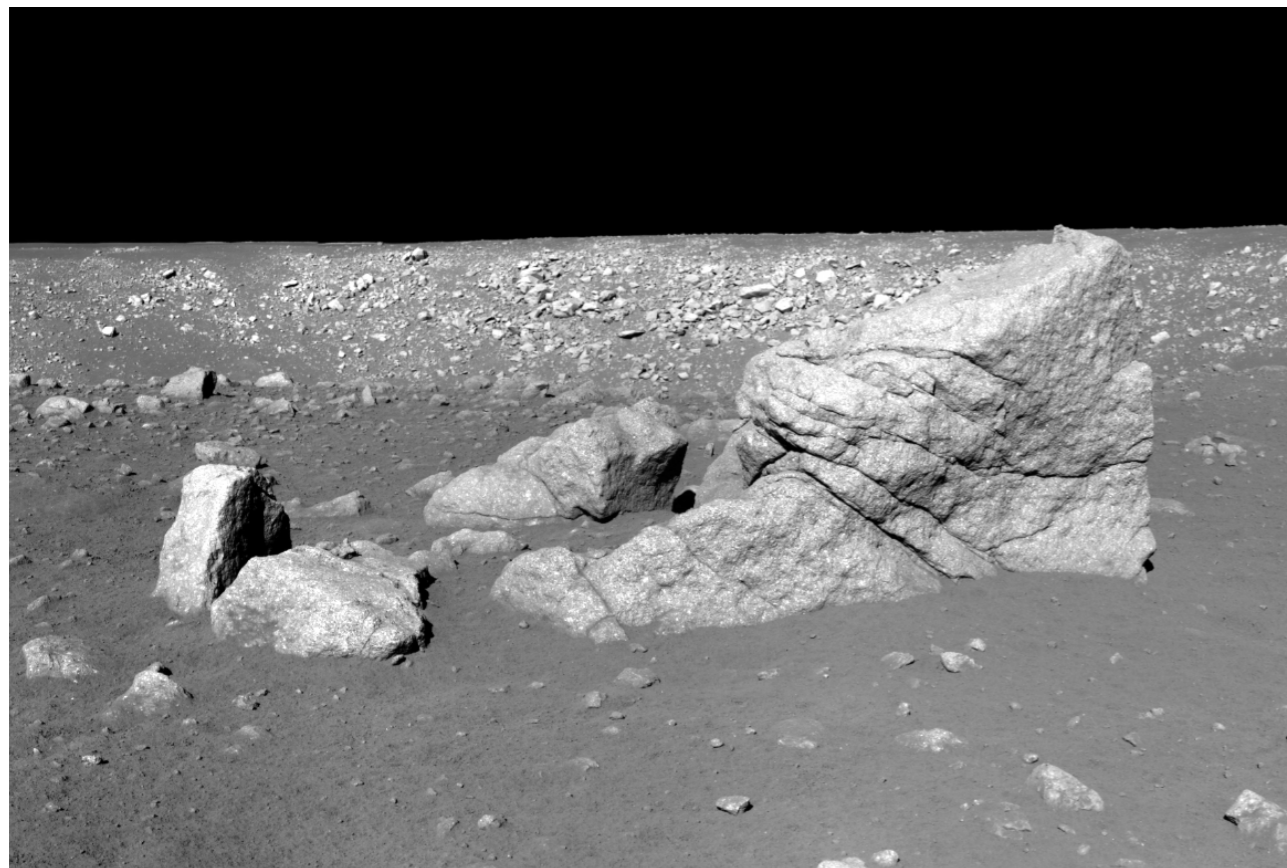

Fig 7.1: lunar surface (2020)

## 7.2 On-earth Relevance

### Everyday of visual & object vertical

Coincidentally, in the last century, De Stijl movement also tricks people's visual vertical of gravity. Buildings on Earth are mostly built with hierarchy (or floors), but when there's no or less "below" or "above" hierarchy, people's cognition, habits, ... will inevitably change as well. Even without gravity, we can still obtain cues for spatial perception because geometry triggers our visual and muscular responses.

### Improve spatial perception

Spatial research could improve design process by taking individual's perception into consideration, encourage design for specific purposes or functions as well as reduce cognitive load. For example design for dementia, or "Neuroarchitecture", enhancing cognitive performance in workspaces.



Fig 7.2: De Stijl movement (1923)

## 8.0 REFERENCES

- Balashova, G. (1980). Topography design for the Mir space station. <http://kvadratinterwoven.com/out-of-this-world-the-space-age-designs-of-galina-balashova>
- BBC (2022). Piet Mondrian artwork displayed upside down for 75 years. <https://www.bbc.com/news/entertainment-arts-63423811>
- ESA. (2019). 3D printing our way to the moon. [https://www.esa.int/Enabling\\_Support/Preparing\\_for\\_the\\_Future/Discovery\\_and\\_Preparation/3D\\_printing\\_our\\_way\\_to\\_the\\_Moon](https://www.esa.int/Enabling_Support/Preparing_for_the_Future/Discovery_and_Preparation/3D_printing_our_way_to_the_Moon)
- ESA. (2020). Spaceship EAC: 3D printing parts for the Moon. <https://blogs.esa.int/exploration/spaceship-eac-3d-printing-parts-for-the-moon/>
- ESA. (2021). Spaceship EAC: turning up the heat on lunar dust <https://blogs.esa.int/exploration/spaceship-eac-turning-up-the-heat-on-lunar-dust/>
- Gibson, J.J. (1979, 2014). Ecological Approach To Visual Perception
- Kleinhenz, J. E., & Paz, A. (2020). Case Studies for Lunar ISRU Systems Utilizing Polar Water. ASCEND 2020. <https://doi.org/10.2514/6.2020-4042>
- Leonard, D. (2022). Leonard David's INSIDE OUTER SPACE. <https://www.leonarddavid.com/artemis-iii-moon-landing-sites-identified/#:~:text=Credit%3A%20NASA,set%20foot%20on%20the%20Moon.>
- Medium (2018). 2001: A Space Odyssey is an experience that is beyond film. <https://medium.com/swish/2001-a-spaceodysseybeyondfilm-f5640fcb898d>
- Morfoisse, T. et, al. (2024). Modality-Independent Effect of Gravity in Shaping the Internal Representation of 3D Space for Visual and Haptic Object Perception <https://www.jneurosci.org/content/jneuro/44/13/e2457202023.full.pdf>
- NASA. (1971). Visual Optics in Space Flight. <https://ntrs.nasa.gov/api/citations/19710024584/downloads/19710024584.pdf>
- NASA. (2015). Regolith-Polymer 3D Printing. <https://technology.nasa.gov/patent/KSC-TOPS-88#:~:text=The%20invention%20consists%20of%20a,joint%20of%20a%20robotic%20arm.&text=The%20feed%20screw%20is%20positioned,polymer%20mixture%20in%20the%20hopper.>
- NASA. (2022). Shackleton Crater's Illuminated Rim & Shadowed Interior. <https://science.nasa.gov/resource/shackleton-craters-illuminated-rim-shadowed-interior/>
- Oman C, M. et, al. (2006). The Role of Visual Cues in Microgravity Spatial Orientation. <https://ntrs.nasa.gov/citations/20030068201>
- Pfeiffer et al. (2016), Visual gravity contributes to subjective first-person perspective. <https://academic.oup.com/nc/article/2016/1/niw006/2757126?login=false>
- St P Walsh, Justin, Alice C. Gorman, and Wendy Salmond. "Visual Displays in Space Station Culture." *Current Anthropology* 62, no. 6 (December 1, 2021): 804–18. <https://doi.org/10.1086/717778>.
- Talmon, et.al. 2016. Affective response to architecture – investigating human reaction to spaces with different geometry. <https://www.tandfonline.com/doi/full/10.1080/0038628.2016.1266597>

# 9.0 REFLECTION

After Millpede's iso-surface calculation, all anchors lose their original direction, making the result mesh unpredictable. This result is likely to be rooted in the original Gyroid calculation method, that  $\sin x \cos y + \sin y \cos z + \sin z \cos x = 0$ , ignored all directional property of vector but automatically blend surfaces regardless of the UV sides.

While potential fix is possible to millpede's source code, this would not be the focus of this project. Instead, by emphasizing, or even reclaim the perception analysis again to the geometry outcome at each stage manually can be less efficient but more appropriate for my project.